

**City of Mission
Regular Meeting Agenda
Wednesday, July 19, 2017
7:00 p.m.
Mission City Hall**

If you require any accommodations (i.e. qualified interpreter, large print, reader, hearing assistance) in order to attend this meeting, please notify the Administrative Office at 913-676-8350 no later than 24 hours prior to the beginning of the meeting.

CALL TO ORDER AND PLEDGE OF ALLEGIANCE

ROLL CALL

PUBLIC HEARING

- Amended Mission Trails Redevelopment Project Plan ([page 3](#))

1. SPECIAL PRESENTATIONS

- Recognition of Betty Benson
- Citizen Appreciation Award Presented to John Arnett

2. ISSUANCE OF NOTES AND BONDS

3. CONSENT AGENDA

*NOTE: Information on consent agenda items has been provided to the Governing Body. These items are determined to be routine enough to be acted on in a single motion; however, this does not preclude discussion. **If a councilmember or member of the public requests, an item may be removed from the consent agenda for further consideration and separate motion.***

CONSENT AGENDA - GENERAL

- 3a. [Minutes of the June 21, 2017 City Council Meeting](#) and [June 28, 2017 Special City Council Meeting](#)

CONSENT AGENDA - Finance & Administration Committee

[Finance & Administration Committee Meeting Packet 7-5-17](#)
[Finance & Administration Committee Meeting Minutes 7-5-17](#)

CONSENT AGENDA - Community Development Committee

[Community Development Committee Meeting Packet 7-5-17](#)
[Community Development Committee Meeting Minutes 7-5-17](#)

COMMUNITY COMMITTEE REPORTS

Approved Minutes from Board and Commission meetings are available on the City of Mission website under the "[Agendas & Minutes](#)" tab.

4. PUBLIC COMMENTS

5. ACTION ITEMS

Planning Commission

Miscellaneous

6. COMMITTEE REPORTS

Finance & Administration, Nick Schlossmacher

[Finance & Administration Committee Meeting Packet 7-5-17](#)

[Finance & Administration Committee Meeting Minutes 7-5-17](#)

Community Development, Kristin Inman

[Community Development Committee Meeting Packet 7-5-17](#)

[Community Development Committee Meeting Minutes 7-5-17](#)

- 6a. Miscellaneous Stormwater Repairs ([page 18](#))
- 6b. Kennett Place Streets - Maintenance Agreement and Release ([page 122](#))

7. UNFINISHED BUSINESS

8. NEW BUSINESS

9. COMMENTS FROM THE CITY COUNCIL

10. MAYOR'S REPORT

11. CITY ADMINISTRATOR'S REPORT

EXECUTIVE SESSION

ADJOURNMENT

Mission Trails

6201 Johnson Drive
Mission Kansas

Amended Redevelopment Plan



June 7, 2017

Table of Contents

1) Introduction

2) Mission Trails Development Project Plan

- a) The Property
- b) Established Development District
- c) Project Description
- d) Financing Plan
- e) Feasibility Study
 - i) Project Costs
 - ii) Eligible Costs
 - iii) Project Revenues
- f) Summary
- g) City of Mission Minutes
- h) Relocation Plan

3) Conclusion

Exhibit List

Exhibit A: TIF Revenue Projections

Exhibit B: Tax Parcel ID

Exhibit C: Legal Description

Exhibit D: Building Elevation and Site Plan

Exhibit E: EPC Real Estate

1. Introduction:

This Redevelopment Project Plan is presented on behalf of Mission Apartments, LLC to redevelop approximately 2.7 acres incorporated within a redevelopment district established in accordance with the Kansas tax increment financing statutes, K.S.A. 12-1770 by the City of Mission on April 19, 2017 via Ordinance No. 1457.

Mission Apartments, LLC as represented by EPC Real Estate Group (“Developer”) plans to redevelop the 2.7 acre property, last occupied by Pyramid Life Insurance in 2008. The building has been vacant since that time.

On December 20, 2016, EPC Real Estate Group, as developer for Mission Apartments, LLC entered into a contract to purchase the property, which contract remains in place. Following approval of the Redevelopment Plan and further upon closing, which is anticipated to occur during the 4th quarter of 2017, Developer expects to commence complete demolition of the existing 46,000 square foot building followed immediately by construction of a single 215,000 square building and a 287 car parking garage consisting of 52 stalls for retail and public and 235 residential stalls.

This project offers several advantages to the City of Mission. First, it will anchor the west side of the downtown area with a new beautiful structure. Second, the economic benefit of adding 200 Class A apartments (approximately 300 people) will have tremendous economic benefit for local retailers and tax revenue for the City. Third, the parking garage will contain public parking spaces to help accommodate parking in the downtown business district as well as at the Sylvester Powell, Jr. Community Center. Fourth, the building’s architecture will complement the “mission” style of architecture already present at Sylvester Powell and other buildings along Johnson Drive. Lastly, the building’s location along Johnson Drive will entice its residents to have street level experiences on a daily basis. That is to walk and ride bikes as much as possible thus reducing dependence on their automobiles. This not only is a very sustainable approach to living it also significantly adds to the overall sense of community.

In total the Mission Trails project, through the use of private debt and equity and TIF, will constitute and investment of over \$40,000,000.

2. Mission Trails Redevelopment Project Plan

a. The Property

The property included in the established Redevelopment District and subject to this plan is a 2.7 acre area within the City of Mission, Kansas located at 6201 Johnson Drive near the intersection of Johnson Drive and Lamar. A portion of the property fronts Beverly Street. Refer to **Exhibit C** for a complete legal description and **Exhibit B** for a map of the boundaries.

b. Established Redevelopment District

The Project comprises the entirety of an established Redevelopment District approved by the City of Mission on April 19, 2017. Boundaries of the Redevelopment District are shown below.



c. Project Description

Mission Trails will consist of a five-story wood frame building with approximately 200 residential units for lease and a structured parking garage with approximately 287 spaces consisting of 52 stalls for retail and public and 235 residential stalls. The total number of spaces, including surface parking is 325 stalls. It is anticipated that a certain number of the spaces (TBD) will be designated as public parking. The building will include a clubhouse with a leasing office on the first floor adjacent to an enclosed courtyard with all the amenities. A second open courtyard is planned on the west side of the building. The building will be mixed-use and include approximately 5,000 square feet of retail along with a 2,500 square foot courtyard fronting on Johnson Drive. Refer to **Exhibit D** for building elevations.

This project will enhance Mission’s downtown area by bringing more residents living in a high-density environment. Furthermore, the 5,000 square feet of retail/restaurants facing an open courtyard will attract Mission residents to the location and thereby enhance the street environment.

Mission Trails will be very similar in quality and character to many of EPC’s other projects in the Kansas City metro area including: Village at Mission Farms, Highlands Lodge in Overland Park, Mission 106 in Leawood, and The Domain in Lenexa. **Refer to Exhibit E.**

Current zoning for the site is MS-1.

EPC anticipates a schedule of 9 months to complete planning, zoning and development incentive approvals and hope to start construction in January 2018. Construction is estimated to take 18 months.

d. Financing Plan

Mission Trails proposes to finance the Project mostly through private financing, both private debt and equity financing. Tax increment financing will provide necessary assistance for eligible expenses as defined herein.

e. Feasibility Study

As required by the TIF Act, a study has been performed to determine if the project benefits will exceed the cost, and the income derived will be sufficient to pay the cost of the project. EPC Real Estate Group, an experienced developer of multifamily projects in the Kansas City area have provided their expertise and experience in income, expense and cost analysis.

i. Project Costs

<u>Project Costs</u>	
<u>Land</u>	\$3,400,000
<u>Hard Costs</u>	
Demo	\$250,000
Building:	\$24,863,563
Garage	\$3,780,000
Site Costs:	
Onsite:	\$1,500,000
Offsite:	<u>\$500,000</u>
Subtotal Hard Cost	\$34,293,562
<u>Soft Costs</u>	
A&E Fees	\$1,157,000
Legal Fees	\$100,000

Financing Fees and Closing	\$250,000
Permit, Fees, Insurance, FF&E	\$1,894,438
Interest	\$1,240,000
Misc Fees	\$531,000
Marketing, Advertising, Commissions	\$250,000
Studies, Inspections and Testing	\$275,000
Contingencies	<u>\$500,000</u>
Subtotal Soft Costs	<u>\$6,197,438</u>
Total Hard and Soft Costs	<u>\$40,491,832</u>

ii. Eligible Costs

According to the TIF Act, only certain costs are eligible to be financed with TIF, with the primary exclusion being vertical development, subject to certain exceptions. The following costs are eligible expenses:

ELIGIBLE PROJECT COSTS

Hard Costs

Land acquisition	\$3,400,000
Demo	\$250,000
Garage	\$3,780,000
Onsite Site Costs	\$1,500,000
Offsite Site Costs	\$500,000
A&E Costs	\$1,157,000
Legal Fees (Est.)	\$100,000
Financing Fees and Closing	\$250,000
Interest During Construction- TIF Share 28%	\$327,200
Contingencies	<u>\$500,000</u>
Total	\$11,784,200

iii. Project Revenues

TIF Revenues will be generated within the district over a period of 20 years and are estimated to generate a total projected property tax increment of \$9,227,820. This calculation is based on 2016 taxes of \$56,066.08 and an assessed value of \$437,001. The current mill levy rate is 122.308, less School and State of 21.5 for a net mill levy of 100.808.

f. Summary

In summary, this project will have a significant impact on the City of Mission. The existing building has deteriorated over time and continues to be vacant. A Conservation Study, prepared by the applicant and confirmed by the City, indicates the property qualifies as a “conservation area” per the TIF Act.

g. City of Mission Minutes

Upon the approval of this plan, the City Clerk shall attach the minutes of all City meetings at which the Project was discussed as **Exhibit F**.

h. Relocation Plan

There are no relocations necessitated by the Project Plan.

3. Conclusion

Mission Trails hereby submits the Plan, as well as all Exhibits hereto, which are incorporated by reference, for consideration at a public hearing in accordance with the TIF Act.

**EXHIBIT A
TIF Revenue Projections- Mission Trails**

Year of TIF (1)	Distribution Year (2)	Total Assessed Value (3)	Base Year Assessed Value (4)	Captured Assessed Value (Column 3 - Column 4) (5)	Projected Property Tax Increment (6)
0	2017	\$437,001	\$437,001	\$0	\$0
1	2018	\$437,001	\$437,001	\$0	\$0
2	2019	\$2,278,207	\$437,001	\$1,841,206	\$185,608
3	2020	\$4,556,415	\$437,001	\$4,119,414	\$415,270
4	2021	\$4,647,543	\$437,001	\$4,210,542	\$424,456
5	2022	\$4,740,494	\$437,001	\$4,303,493	\$433,827
6	2023	\$4,835,304	\$437,001	\$4,398,303	\$443,384
7	2024	\$4,932,010	\$437,001	\$4,495,009	\$453,133
8	2025	\$5,030,650	\$437,001	\$4,593,649	\$463,077
9	2026	\$5,131,263	\$437,001	\$4,694,262	\$473,219
10	2027	\$5,233,889	\$437,001	\$4,796,888	\$483,565
11	2028	\$5,338,566	\$437,001	\$4,901,565	\$494,117
12	2029	\$5,445,338	\$437,001	\$5,008,337	\$504,880
13	2030	\$5,554,244	\$437,001	\$5,117,243	\$515,859
14	2031	\$5,665,329	\$437,001	\$5,228,328	\$527,057
15	2032	\$5,778,636	\$437,001	\$5,341,635	\$538,480
16	2033	\$5,894,209	\$437,001	\$5,457,208	\$550,130
17	2034	\$6,012,093	\$437,001	\$5,575,092	\$562,014
18	2035	\$6,132,335	\$437,001	\$5,695,334	\$574,135
19	2036	\$6,254,981	\$437,001	\$5,817,980	\$586,499
20	2037	\$6,380,081	\$437,002	\$5,943,079	\$599,110
Total Projected Property Tax Increment					\$9,227,820

Anticipated Assessed and Appraised Values:

Use	# of Units	Year of Completion	Appraisal Value	Assessment Rate	Assessed Value
Apartments	200	2020	\$39,621,000	11.5%	\$4,556,415
Totals			\$39,621,000		\$4,556,415
				Current Mill Levy	122.308
				Less Sch/State	21.500
				Net Mill Levy	100.808

Assumptions:

- a) Development is fully stabilized on 1/1/2021 valuation date.
- b) Fully stabilized development generates property taxes of \$2,551 per unit annually.
- c) Appraised value increases by 2% annually after fully stabilized.
- d) Property tax collection rate will be 100%.
- e) Property tax increment is distributed twice each year.

EXHIBIT B

Tax Parcel ID: KF251208-4005

Legal Desc. 8-12-25 BG 825' W NE CR NW1/4 SE1/4 W 330' S 300' W 167.13' S 75' E 636.73' N 165' W 140' N 210' TO
(abbreviated) POB EX .29 AC & EX .1 AC 3.275 ACS ML

Property Map for KF251208-4005



EXHIBIT C

Legal Description

ALL THAT PART OF THE NORTHWEST QUARTER OF THE SOUTHEAST QUARTER (NW 1/4, SE 1/4) OF SECTION 8, TOWNSHIP 12, RANGE 25, IN MISSION, JOHNSON COUNTY, KANSAS, DESCRIBED AS FOLLOWS:

BEGINNING AT A POINT ON THE NORTH LINE OF SAID 1/4, 1/4 SECTION THAT IS S 87° 59' 16" W 824.08' (825' DEED) WEST OF THE NORTHEAST CORNER THEREOF; THENCE S 2° 04' 52" E, PARALLEL TO THE EAST LINE OF SAID 1/4, 1/4 SECTION 60.00' TO A POINT ON THE SOUTH LINE OF JOHNSON DRIVE, AS ESTABLISHED; THENCE S 87° 59' 16" W ALONG SAID SOUTH LINE, 1.00', SAID POINT BEING THE TRUE POINT OF BEGINNING OF THIS TRACT; THENCE S 2° 04' 52" E 180.00'; THENCE N 87° 59' 16" E, PARALLEL TO SAID NORTH LINE, 141.00' FEET TO A POINT 684.08' (685' DEED) WEST OF SAID EAST LINE OF SAID 1/4, 1/4 SECTION, BEING ALSO ON THE WEST LINE OF BEVERLY AVE., AS ESTABLISHED; THENCE S 2° 04' 52" E ALONG SAID WEST LINE, AND PARALLEL TO THE EAST LINE OF SAID 1/4, 1/4 SECTION, 135.00' TO A POINT 375.00' SOUTH OF SAID NORTH LINE; THENCE S 87° 59' 16" W, PARALLEL TO SAID NORTH LINE, 470.00' TO A POINT 167.23' (167.13', MORE OR LESS, DEED) EAST OF THE WEST LINE OF SAID 1/4, 1/4 SECTION; THENCE N 2° 04' 52" W 315.00' TO A POINT ON THE SOUTH LINE OF SAID JOHNSON DRIVE, AS ESTABLISHED, 60.00' SOUTH OF THE NORTH LINE OF SAID 1/4, 1/4 SECTION, SAID POINT BEING ALSO 167.39' (167.13' DEED) EAST OF THE WEST LINE OF SAID 1/4, 1/4 SECTION; THENCE N 87° 59' 16" E ALONG SAID SOUTH LINE, 329.00' TO THE POINT OF BEGINNING.

THE ABOVE DESCRIBED TRACT CONTAINS 122,759 SQUARE FEET, OR, 2.8181 ACRES, MORE OR LESS.

EXHIBIT D

Building elevation looking east:



View along Johnson Drive looking west. The corner is an open plaza contiguous to retail

Site Plan:

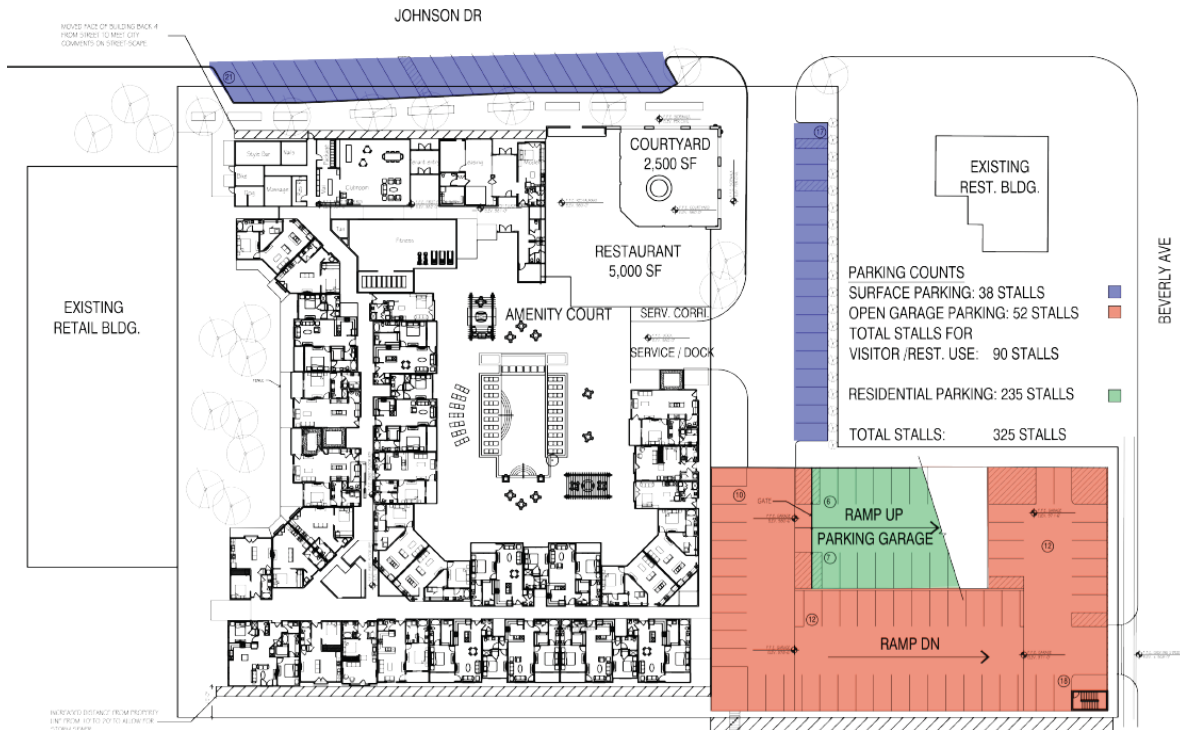

EXHIBIT E

EPC Real Estate Group Description:

In general, EPC specializes in identifying infill locations in both urban and suburban markets. We select locations that are walkable, convenient, and have great access. Downtown Mission, Kansas is exactly that type of neighborhood. EPC designs a product that is not viewed as a typical apartment. Our customer is looking for a special place to live. That is, a building in a walkable community that is constructed of high quality materials and finishes. When combined with the appropriate mix of amenities our projects attract renters of all ages who were not necessarily part of the renter pool for existing apartments.

Developer Organizational Structure: EPC consists of approximately 50 employees. Jobs range from lawn maintenance, sales, leasing, and management. The following shows upper management positions.

Example of two of EPC's recent developments in the KC metro area:

Avenue 80



Project Mix	218 Units – 15,443 SF of Office / Retail
Location	80th & Metcalf, Overland Park, KS <ul style="list-style-type: none">• Adjacent to Historic Downtown Overland Park.• Extremely walkable small town Main Street with Farmers Market.
Unique Features	Four story full garage wrap with office tower integrated into building with street level retail. 5th floor club level for entertaining and meetings.
Status	Commenced: June 2015 Completion: January 2017
Cost	\$42 Million
Developer	EPC

51MAIN



Project Mix	176 Units – 9,000 SF of Retail
Location	51st & Main St, Kansas City, Missouri <ul style="list-style-type: none">• True Neighborhood Main Street environment with many of Kansas City's Favorite Restaurants.
Unique Features	Four to eight story garage wrap with two level courtyard featuring infinity pool. Street level retail complements the already vibrant pedestrian space.
Status	Completed: March 2015, in Lease-Up Stabilized: November 2015
Cost	\$41 Million
Developer	EPC / VanTrust



Terence O'Leary
Steve Coon
Michael McKeen



| Terence O'Leary



| Steve Coon



| Michael McKeen

EPC specializes in identifying opportunities to acquire land and create unique projects in the marketplace that deliver the "WOW Factor". By branding, differentiating and marketing our projects, EPC has had great success with project lease-up and since being formed in 1999.

Terence P. O'Leary and Steven W. Coon, as principals of EPC, provide full development services on each project including planning and zoning approvals, design, construction management, leasing and sales. With over 60 years of combined experience, Terry and Steve provide the ability to interpret market demand factors, procure land, and develop almost any type of commercial or residential project. Both are directly involved in all aspects of the project and pride themselves in the ability to assemble a team of experts to execute all facets of the development. As developers, EPC understands its responsibility for environmentally conscious development and as a result incorporates many of the industries best practices in its designs.

Vision

The EPC vision is centered on an in depth understanding of market demand factors unique to a site and designing a project to match that demand. Our core belief is recognizing that there is always a better way to plan, build and market property.

Awards and Recognition

EPC's first project, BarreWoods, won the Kansas City Apartment Association's highest achievement, "Outstanding Overall Apartment Property" three consecutive years, 2006 – 2008. BarreWoods also won thirteen Awards of Excellence, more than any other apartment property in the Kansas City metropolitan area.

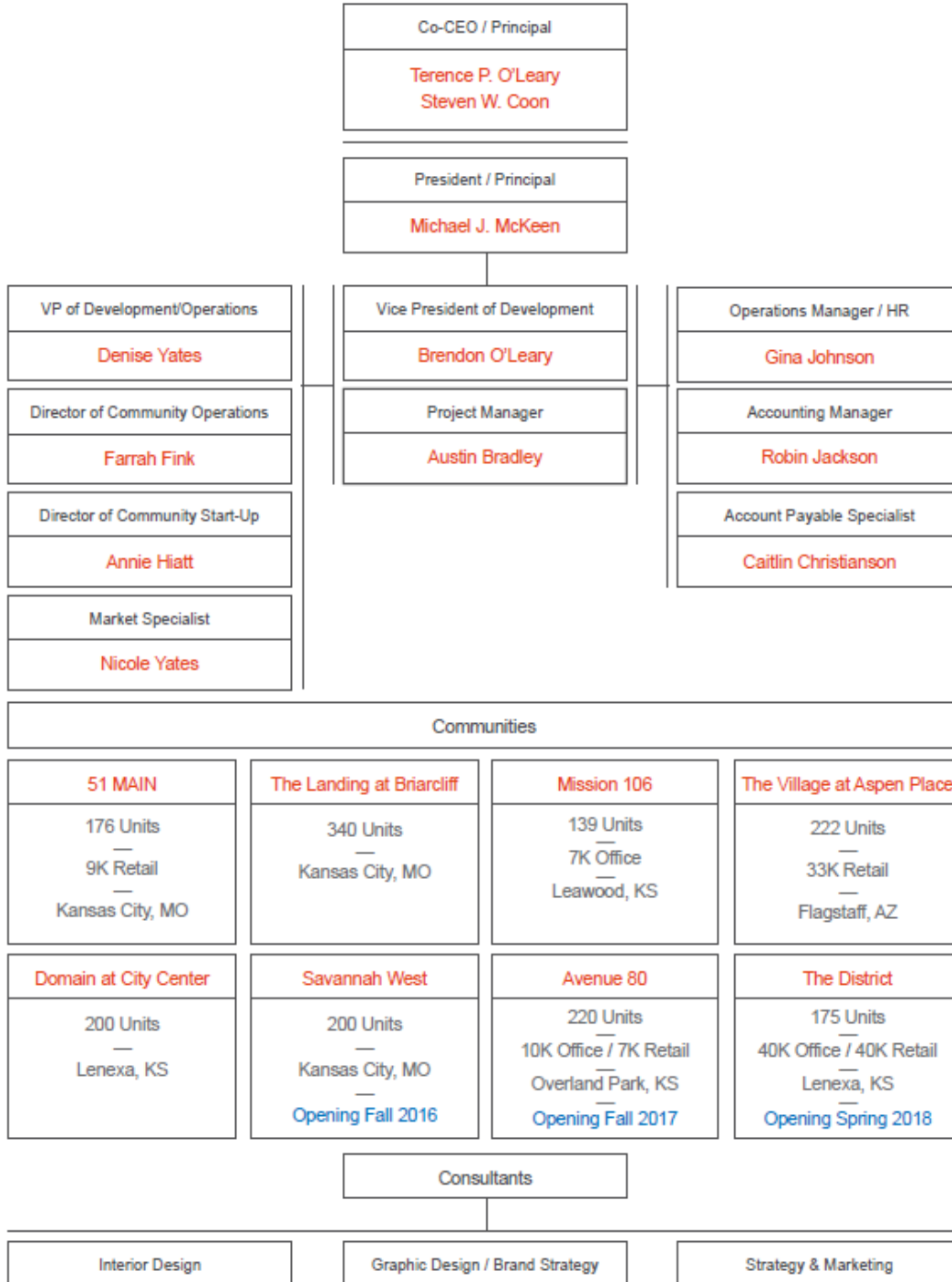

City of Mission	Item Number:	6a.
ACTION ITEM SUMMARY	Date:	June 30, 2017
Public Works	From:	John Belger

Action items require a vote to recommend the item to full City Council for further action.

RE: Miscellaneous Stormwater Repairs - 2017

RECOMMENDATION: Approve the contract with Pyramid Excavation and Construction for repairs to two storm drainage infrastructure failures in an amount not to exceed \$124,927.

DETAILS: Last September, Council authorized a task order with GBA to provide survey, design and bid phase services for three stormwater infrastructure failures. Sinkholes had formed adjacent to these failures causing unsafe conditions for the public. This contract will address failures at the following locations:

6500 W. 51st Street - A corrugated metal pipe failed underneath the sidewalk on the north side of 51st Street. This caused the subgrade under the sidewalk to erode and has compromised the structural integrity of the sidewalk.

5820 W. 61st Terrace - The clay stormwater pipe in this area failed in multiple locations, causing a sinkhole adjacent to the street and beneath the landscaping of the home at this location.

The third failure will be addressed with the Foxridge project that has been bid and awarded and will be completed later this year.

The miscellaneous stormwater repair projects were advertised and bids were opened on June 29th, 2017. There were six (6) bidders, with Pyramid Excavation & Construction being the lowest and most responsive respondent.

Miscellaneous Stormwater Repairs - Bid Opening Results June 29th, 2017	
Kissick	\$195,711.00
Westland	\$140,099.88
Pyramid Excavation	\$124,927.00
Kansas Heavy	\$129,779.00
Linaweaver	\$155,335.00
Blue Nile Contractors	\$164,967.07

CFAA CONSIDERATIONS/IMPACTS: N/A

Related Statute/City Ordinance:	
Line Item Code/Description:	
Available Budget:	\$150,000

BID

2017 STORM SEWER POINT REPAIRS, CONTRACT 1

TO: CITY OF MISSION,
JOHNSON COUNTY, KANSAS

Neither the City nor Consultant shall be responsible for the accuracy, completeness, or sufficiency of any bid documents obtained from any source other than the source indicated in the Notice to Bidders. Obtaining copies of plans, specifications, bid documents and other contract documents from any other source(s) may result in obtaining incomplete and inaccurate information. Obtaining these documents from any source other than directly from the source listed in the Notice to Bidders may also result in failure to receive any addenda, corrections, or other revisions to these documents that may be issued.

The undersigned bidder hereby proposes to mobilize and furnish all materials, supplies, transportation, tools, equipment and plant, perform all necessary labor and construct, install and complete all work stipulated in, required by, and in conformity with the proposed contract documents (including all documents referred to therein) and any and all addenda thereto, for and in consideration of prices as follows:

ITEM NO.	ITEM DESCRIPTION	UNIT	QUANTITY	UNIT COST \$	COST \$
1	Base Bid - 5820 W 61st Terrace	1	L.S.	15,000.00	15,000.00
2	Base Bid - 6500 W 51st Street	1	L.S.	15,000.00	15,000.00
3	15" RCP with O-Ring Gaskets and Bedding	33	L.F.	110.00	3,630.00
4	18" RCP with O-Ring Gaskets and Bedding	331	L.F.	115.00	38,065.00
5	24" RCP with O-Ring Gaskets and Bedding	168	L.F.	120.00	20,160.00
6	4' Diameter Precast Storm Manhole	2	Ea.	1.00	2.00
7	4'x3' Precast Curb Inlet	4	Ea.	5,000.00	20,000.00
8	Trench Backfill and Restoration, Unpaved Area	378	L.F.	15.00	5,670.00
9	Trench Backfill and Restoration, Paved Area	148	L.F.	50.00	7,400.00

TOTAL BID \$ 124,927.00

1. The undersigned further agrees to begin upon the date stated in the Notice to Proceed and to complete the work, if this bid is accepted, no later than June 30, 2017 subject to the conditions set forth in paragraph SC-19, CONSTRUCTION TIMELINE AND LIMITATIONS, of the Project Special Conditions.

The undersigned also declares that it understands that if not preset by the City the time to begin construction and to complete the work will be one factor considered in determining the lowest and best responsible bidder.

The undersigned also declares that he/she understands that liquidated damages based on the full bid price of the contract shall be assessed against Contractor, as stipulated liquidated damages and not as a penalty, in an amount as set forth in paragraph GC-46 of the General Conditions for each and every calendar day the work remains incomplete over the specified completion time(s).

2. In submitting this bid, the undersigned declares that it is of lawful age and executed the accompanying bid on behalf of the bidder therein named, and that it had lawful authority so to do. The undersigned further declares that it has not directly or indirectly entered into any agreement, expressed or implied, with any bidder or bidders, having for its object the controlling of the price or amount of such bid or any bids, the limiting of the bid or bidders, the parceling or farming out to any bidder or bidders, or other persons, of any part of the contract or any part of the subject matter of the bid or bids or of the profits thereof, and that it has not and will not divulge the sealed bid to any person whomsoever, except those having a partnership or other financial interest with bidder in said bid or bids, until after sealed bid or bids are opened.
3. The undersigned further declares that it has carefully examined the Notice to Bidders, Instructions to Bidders and other contract documents, and that it has inspected the actual location of the work, together with the local sources of supply, and has satisfied itself as to all conditions and quantities, and understands that in signing this Bid it waives all right to plead any misunderstanding regarding the same.
4. The undersigned hereby agrees to furnish the required bonds and insurance certificates and execute an agreement within ten (10) calendar days from and after notice of the award of the contract, and failure of the bidder to do so shall constitute a default, and the City may thereafter take such steps to protect its legal rights as it deems in its best interest, including, but not limited to, enforcement of its rights as to bid security.
5. It is understood that the City will pay in a prompt and timely manner pay estimates when submitted and approved by the Architect/Engineer and further approved by the City staff coordinator for the project, all as provided in the contract documents.
6. Undersigned acknowledges receipt of the Plans and Specifications for the project including the following addenda (complete) _____
ADDENDUM - NO. 1 DATA 6-29-17

Enclosed is a certified check, cashier's check or bid bond in the amount of

5% OF BID AMOUNT
DOLLARS (\$ _____) which the undersigned agrees is subject to being forfeited to and becoming the property of the City as liquidated damages and not as a penalty, together with other legal remedies the City may choose to invoke, all as set forth in the Instructions to Bidders Section IB-9, should this Bid be accepted and the contract be awarded to this bidder and it should fail to enter into an agreement in the form prescribed and to furnish the required insurance, bonds and other required documents within ten (10) calendar days as above stipulated, otherwise the bid security shall be returned to the undersigned upon signing of the agreement and delivery of the approved bonds and other required documents to the City of Mission, Kansas.

DATED in PYRAMID'S OFFICE this 29th day of JUNE, 2017.

(SEAL)

PYRAMID EXCAVATION & CONSTRUCTION, INC.

Contractor

Signature

ROBERT C. YUNGER PRESIDENT

Printed Name

Title

11102 HICKMAN MILLS DR

Street Address or P.O. Box

KANSAS CITY, MO 64134

City, State, Zip

Telephone Number

816-765-4464

Fax Number

816-765-4467

AIA[®] Document A310[™] – 2010

Bid Bond

CONTRACTOR:

(Name, legal status and address)

Pyramid Excavation & Construction, Inc.
11102 Hickman Mills Dr.
Kansas City, MO 64134

SURETY:

(Name, legal status and principal place of business)

Merchants National Bonding, Inc.
6700 Westown Pkwy
West Des Moines, IA 50266

OWNER:

(Name, legal status and address)

City of Mission, Kansas
6090 Woodson Street
Mission, KS 66202

BOND AMOUNT: Five percent (5%) of the amount bid.

PROJECT:

(Name, location or address, and Project number, if any)

2017 Storm Sewer Repairs, Contract 1

This document has important legal consequences. Consultation with an attorney is encouraged with respect to its completion or modification.

Any singular reference to Contractor, Surety, Owner or other party shall be considered plural where applicable.

The Contractor and Surety are bound to the Owner in the amount set forth above, for the payment of which the Contractor and Surety bind themselves, their heirs, executors, administrators, successors and assigns, jointly and severally, as provided herein. The conditions of this Bond are such that if the Owner accepts the bid of the Contractor within the time specified in the bid documents, or within such time period as may be agreed to by the Owner and Contractor, and the Contractor either (1) enters into a contract with the Owner in accordance with the terms of such bid, and gives such bond or bonds as may be specified in the bidding or Contract Documents, with a surety admitted in the jurisdiction of the Project and otherwise acceptable to the Owner, for the faithful performance of such Contract and for the prompt payment of labor and material furnished in the prosecution thereof; or (2) pays to the Owner the difference, not to exceed the amount of this Bond, between the amount specified in said bid and such larger amount for which the Owner may in good faith contract with another party to perform the work covered by said bid, then this obligation shall be null and void, otherwise to remain in full force and effect. The Surety hereby waives any notice of an agreement between the Owner and Contractor to extend the time in which the Owner may accept the bid. Waiver of notice by the Surety shall not apply to any extension exceeding sixty (60) days in the aggregate beyond the time for acceptance of bids specified in the bid documents, and the Owner and Contractor shall obtain the Surety's consent for an extension beyond sixty (60) days.

If this Bond is issued in connection with a subcontractor's bid to a Contractor, the term Contractor in this Bond shall be deemed to be Subcontractor and the term Owner shall be deemed to be Contractor.

When this Bond has been furnished to comply with a statutory or other legal requirement in the location of the Project, any provision in this Bond conflicting with said statutory or legal requirement shall be deemed deleted herefrom and provisions conforming to such statutory or other legal requirement shall be deemed incorporated herein. When so furnished, the intent is that this Bond shall be construed as a statutory bond and not as a common law bond.

Signed and sealed this 29th day of June, 2017

(Witness)

(Principal) **ROBERT C. YUNGER PRESIDENT** (Seal)

(Title)

(Witness)

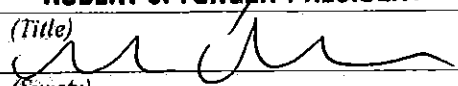
(Surety) (Seal)

Attorney in fact, David S. Salavitch
(Title)

Init.

MERCHANTS
BONDING COMPANYTM
POWER OF ATTORNEY

Know All Persons By These Presents, that MERCHANTS BONDING COMPANY (MUTUAL) and MERCHANTS NATIONAL BONDING, INC., both being corporations of the State of Iowa (herein collectively called the "Companies") do hereby make, constitute and appoint, individually,

David S Salavitch; Luke P Sealer; Robert L Cox II

their true and lawful Attorney(s)-in-Fact, to sign its name as surety(ies) and to execute, seal and acknowledge any and all bonds, undertakings, contracts and other written instruments in the nature thereof, on behalf of the Companies in their business of guaranteeing the fidelity of persons, guaranteeing the performance of contracts and executing or guaranteeing bonds and undertakings required or permitted in any actions or proceedings allowed by law.

This Power-of-Attorney is granted and is signed and sealed by facsimile under and by authority of the following By-Laws adopted by the Board of Directors of Merchants Bonding Company (Mutual) on April 23, 2011 and amended August 14, 2015 and adopted by the Board of Directors of Merchants National Bonding, Inc., on October 16, 2015.

"The President, Secretary, Treasurer, or any Assistant Treasurer or any Assistant Secretary or any Vice President shall have power and authority to appoint Attorneys-in-Fact, and to authorize them to execute on behalf of the Company, and attach the seal of the Company thereto, bonds and undertakings, recognizances, contracts of indemnity and other writings obligatory in the nature thereof."

"The signature of any authorized officer and the seal of the Company may be affixed by facsimile or electronic transmission to any Power of Attorney or Certification thereof authorizing the execution and delivery of any bond, undertaking, recognizance, or other suretyship obligations of the Company, and such signature and seal when so used shall have the same force and effect as though manually fixed."

In connection with obligations in favor of the Florida Department of Transportation only, it is agreed that the power and authority hereby given to the Attorney-in-Fact includes any and all consents for the release of retained percentages and/or final estimates on engineering and construction contracts required by the State of Florida Department of Transportation. It is fully understood that consenting to the State of Florida Department of Transportation making payment of the final estimate to the Contractor and/or its assignee, shall not relieve this surety company of any of its obligations under its bond.

In connection with obligations in favor of the Kentucky Department of Highways only, it is agreed that the power and authority hereby given to the Attorney-in-Fact cannot be modified or revoked unless prior written personal notice of such intent has been given to the Commissioner-Department of Highways of the Commonwealth of Kentucky at least thirty (30) days prior to the modification or revocation.

In Witness Whereof, the Companies have caused this instrument to be signed and sealed this 5th day of April, 2017.



MERCHANTS BONDING COMPANY (MUTUAL)
MERCHANTS NATIONAL BONDING, INC.

By *Larry Taylor*
President

STATE OF IOWA
COUNTY OF DALLAS ss.

On this this 5th day of April 2017, before me appeared Larry Taylor, to me personally known, who being by me duly sworn did say that he is President of MERCHANTS BONDING COMPANY (MUTUAL) and MERCHANTS NATIONAL BONDING, INC.; and that the seals affixed to the foregoing instrument are the Corporate Seals of the Companies; and that the said instrument was signed and sealed in behalf of the Companies by authority of their respective Boards of Directors.

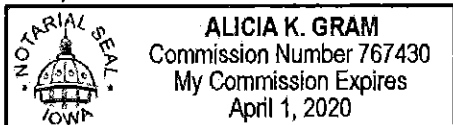

Alicia K. Gram
Notary Public

(Expiration of notary's commission does not invalidate this instrument)

I, William Warner, Jr., Secretary of MERCHANTS BONDING COMPANY (MUTUAL) and MERCHANTS NATIONAL BONDING, INC., do hereby certify that the above and foregoing is a true and correct copy of the POWER-OF-ATTORNEY executed by said Companies, which is still in full force and effect and has not been amended or revoked.

In Witness Whereof, I have hereunto set my hand and affixed the seal of the Companies on this 29th day of June, 2017



William Warner Jr.
Secretary



Invitation to Bid / Project Manual

for

**2017 STORM SEWER POINT REPAIRS
CONTRACT 1**

Published: June 15, 2017

Proposals Due: June 29, 2017



CITY OF MISSION
SPECIFICATIONS
CONTRACT DOCUMENTS

2017 STORM SEWER POINT REPAIRS, CONTRACT 1

TABLE OF CONTENTS

SUBJECT	PAGE TO PAGE (INCLUSIVE)
Notice to Bidders	N-1 to N-2
Instructions to Bidders	I-1 to I-9
Bid Form	B-1 to B-3
Agreement	A-1 to A-3
Performance Bond	P-1 to P-2
Maintenance Bond	M-1 to M-2
Statutory Bond	SB-1 to SB-2
Labor and Material Payment Bond	L-1 to L-2
General Conditions – Table of Contents	G-i to G-ii
General Conditions	G-1 to G-36
Project Special Conditions – Table of Contents	PSC-i
Project Special Conditions	PSC-1 to PSC-9
Storm Drainage Specifications	02630-1 to 02630-4
Site Clearing Specifications	02230-1 to 02230-4
Photographic Documentation Specifications	01322-1 to 01322-3
Construction Plans and Documents	3 Sheets
Overland Park Construction Details (36x24 sized)	9 Sheets

CITY OF MISSION, KANSAS

NOTICE TO BIDDERS

Sealed bids for **2017 STORM SEWER POINT REPAIRS, CONTRACT 1** will be received by the City of Mission, Kansas, at the office of the City Clerk, City Hall, 6090 Woodson Street, Mission, Kansas 66202 until 2:30 p.m. local time on **THURSDAY, JUNE 29, 2017**. At that time all sealed bids will be transferred to the **City Council Chamber**, City Hall, where they will be publicly opened and read aloud. Any bid received after the designated closing time will be returned unopened.

All bids shall be submitted in sealed envelopes addressed to the City Clerk of Mission, Kansas, and marked "**2017 STORM SEWER POINT REPAIRS**". Contractors desiring the Contract Documents for use in preparing bids may obtain a set of such documents from the **City of Mission, Kansas, Public Works Department, email jbelger@missionks.org with subject line reading "BID FOR 2017 STORM SEWER POINT REPAIRS, CONTRACT 1"**. Proposers should specifically note the City of Mission prefers questions be submitted by email.

Neither the City nor consultant shall be responsible for the accuracy, completeness, or sufficiency of any bid documents obtained from any source other than the source indicated above. Obtaining copies of plans, specifications, bid documents and other contract documents from any other source(s) may result in obtaining incomplete and inaccurate information. Obtaining these documents from any source other than directly from the source listed herein may also result in failure to receive any addenda, corrections, or other revisions to these documents that may be issued.

Contractors should read and be fully familiar with all contract documents before submitting a bid. In submitting a bid, the bidder warrants that it has read the contract documents and is fully familiar therewith and that it has visited the site of the work to fully inform itself as to all existing conditions and limitations and shall include in its bid a sum to cover the cost of all items of the work.

Should a bidder find "defects" as defined in paragraph GC-3 of the General Conditions, it shall follow the procedures outlined in paragraph GC-3 to bring same to the attention of City. Changes necessitated thereby shall be in the form of addenda issued by the consultant.

All bidders shall verify that they have considered all written addenda. Neither the City nor the consultant shall be responsible for oral instructions.

Any written addenda issued during the time of bidding shall be covered and included in the bid. There will be no clarifications or exceptions allowed on the bid. Bids are for a total bid package, total contract price.

Bids shall be made upon the form provided in ink or typewritten. Numbers shall be stated both in writing and in figures; the signature shall be long hand; and the complete form shall be without alteration or erasure. On alternate items for which a bid is not submitted, a written indication of "no bid" on the bid form is required.

No oral, telegraphic, facsimile, electronic, or telephonic bids or alterations will be considered.

The following items must be included in the sealed envelope with the bid:

- a. Bid
- b. 5% Bid Security--Bid Bond, Cashier's Check or Certified Check (See below.)

Each bidder shall file with its bid a bid bond, a cashier's check or a certified check drawn on any acceptable bank, made payable to the City of Mission, Kansas, in an amount of not less than five percent (5%) of the total bid, which shall be retained by the City of Mission until a contract for the project has been executed. Bid bonds will be returned to the unsuccessful bidders, with the exception of the second qualifying bidder, at such time as their bids are rejected. The bid deposit of the successful bidder and the second qualifying bidder will be returned when satisfactory bonds in an amount equal to 100% of the contract amount, required insurance certificates and other required documents shall have been furnished and the contract documents have been executed.

In the event the successful bidder is unable to execute the contract, for whatever reason, City may exercise its legal prerogatives, including, but not limited to, enforcement of its rights as to the bid security.

The City reserves the right to accept or reject any and all bids and to waive any technicalities or irregularities therein. Bids may be modified or withdrawn by written request of the bidder received in the office of the City Clerk, prior to the time and date for bid opening; provided, however, that no bidder may withdraw its bid for a period of thirty (30) days from the date set for the opening thereof. ALL BIDDERS AGREE THAT REJECTION SHALL CREATE NO LIABILITY ON THE PART OF THE CITY BECAUSE OF SUCH REJECTION. IT IS UNDERSTOOD BY ALL BIDDERS THAT AN UNSUCCESSFUL BIDDER HAS NO CAUSE OF ACTION AGAINST THE CITY FOR BID PREPARATION COSTS. THE FILING OF ANY BID IN RESPONSE TO THIS INVITATION SHALL CONSTITUTE AN AGREEMENT OF THE BIDDER TO THESE CONDITIONS.

A Pre-Bid Conference will not be held.

INSTRUCTIONS TO BIDDERS

- IB-1. **BIDS:** All bids shall be made on the forms provided in this bound volume of contract documents and shall be in compliance with the Notice to Bidders. All appropriate blanks shall be filled in and shall be signed by the appropriate individual on behalf of him/herself or the entity submitting the bid. Each bid must be enclosed in a sealed envelope plainly marked "**2017 STORM SEWER POINT REPAIRS, CONTRACT 1**". As per the Notice to Bidders, bid shall be addressed to:

CITY OF MISSION, KANSAS
Attention: City Clerk
6090 Woodson Street,
Mission, KS 66202

IB-2. **DEFINITIONS:**

- a. All definitions set forth in the General Conditions or in other contract documents are applicable to the Bidding Documents.
- b. "Alternative Bid" (or "Alternate") means an amount stated in the Bid to be added to or deducted from the amount of the Base Bid if the corresponding change in the work, as described in the Bidding Documents, is accepted.
- c. "Base Bid" means the sum stated in the Bid for which the Bidder offers to perform the work described in the Bidding Documents as the base, to which work may be added or from which work may be deleted for sums stated in Alternate Bids.
- d. "Bid" shall mean the offer or proposal of the Bidder submitted on the prescribed form setting forth the prices for the work to be performed (and the City reserves the right to reject any and all bids).
- e. "Bidder" shall mean any individual, partnership, corporation, association or other entity submitting a Bid for the work.
- f. "Bidding Documents" shall mean all documents related to a Bidder's submitting a Bid, including, but not limited to, the advertisement for Bids, if applicable, Instructions to Bidders, the Bid form, other sample bidding and contract forms and the proposed contract documents, including any addenda issued prior to receipt of Bids. At the City's option, Bidders may be required to complete and submit a prequalification statement.
- g. "City" means the City of Mission, Kansas.
- h. "Contractor" shall mean the entity entering into the contract for the performance of the work covered by the contract, together with its duly authorized agents or legal representatives.
- i. "Successful Bidder" means the person or entity who is determined and declared by the City to have submitted the lowest and best responsible Bid in conformity with the terms of the Bidding Documents.

- j. "Unit Price" means an amount stated in the Bid as a price per unit of measurement for materials or services as described in the Bidding Documents or in the proposed contract documents.

IB-3. BIDDER'S REPRESENTATIONS: Each Bidder by making its Bid represents that:

- a. It has read and understands the Bidding Documents, and its Bid is made in accordance therewith.
- b. It has visited the site, has familiarized itself with the local conditions under which the work is to be performed, has reviewed all published reports, inspections and other documents relating to the project and has correlated its observations with the requirements of the proposed contract documents.
- c. Its Bid is based upon the materials, systems and equipment required by the Bidding Documents without exception.
- d. It has familiarized itself with state, federal law and local ordinances, regulations, and permitting requirements which may affect cost and/or progress or performance of the work.

IB-4. BIDDING DOCUMENTS: Bidders may obtain complete sets of the Bidding Documents from the City or the consultant for the sum stated in the Notice to Bidders. Neither the City nor the consultant shall be responsible for the accuracy, completeness, or sufficiency of any Bidding Documents obtained from any source other than the source indicated in the Notice to Bidders. Obtaining copies of Bidding Documents from any other source(s) may result in obtaining incomplete and inaccurate information or result in failure to receive any addenda, corrections, or other revisions to these documents that may be issued.

Bidders shall use complete sets of Bidding Documents in preparing Bids; neither the City nor the consultant assumes any responsibility for errors or misinterpretations resulting from the use of incomplete sets of Bidding Documents.

The City in making copies of the Bidding Documents available on the above terms does so only for the purpose of obtaining Bids on the work and does not confer a license or grant for any other use.

IB-5. DEFECTS IN BIDDING DOCUMENTS: Bidders shall promptly notify the City of any errors, omissions, discrepancies or inconsistencies (hereinafter "defects") which they may discover upon examination of the Bidding Documents or of the site and local conditions. Bidders will not be permitted to take advantage of any such defect.

Bidders requiring clarification or interpretation of the Bidding Documents shall make a written request which shall reach the consultant at least seven days prior to the date for receipt of Bids.

Any interpretation, correction or change of the Bidding Documents will be made by Addendum. Interpretations, corrections or changes of the Bidding Documents made in any other manner will not be binding, and Bidders shall not rely upon such interpretations, corrections and changes.

- IB-6. SUBSTITUTIONS: The materials, products and equipment described in the Bidding Documents establish a standard of required function, dimension, appearance and quality to be met by any proposed substitution.

No substitution will be considered prior to receipt of Bids unless written request for approval has been received by the consultant at least seven (7) days prior to the date for receipt of Bids. Each such request shall include the name of the material or equipment for which it is to be substituted and a complete description of the proposed substitute including drawings, cuts, performance and test data and any other information necessary for an evaluation. A statement setting forth any changes in other materials, equipment or other work that incorporation of the substitute would require shall be included. The burden of proof of the merit of the proposed substitute is upon the Bidder. The consultant's decision of approval or disapproval of a proposed substitution shall be final.

If the consultant approves any proposed substitution prior to receipt of Bids, such approval will be set forth in a written addendum. Bidders shall not rely upon approvals made in any other manner.

No substitutions will be considered after the contract award unless specifically provided in the contract documents (see GC-61).

- IB-7. ADDENDA: Written addenda will be mailed or delivered to all who are known by the consultant to have received a complete set of Bidding Documents.

Copies of written addenda will be made available for inspection wherever Bidding Documents are on file for that purpose.

No written addenda will be issued later than four (4) days prior to the date for receipt of Bids except an addendum withdrawing the request for Bids or one which includes postponement of the date for receipt of Bids.

Each Bidder shall ascertain prior to submitting its Bid that it has received all written addenda issued, and it shall acknowledge its receipt in its Bid.

- IB-8. INSURANCE:

- a. General: The Contractor shall secure and maintain, throughout the duration of the agreement, insurance (on an occurrence basis unless otherwise agreed to) of such types and in at least such amounts as required herein. Contractor shall provide certificates of insurance and renewals thereof on forms provided by the City or on forms acceptable to the City. The City shall be notified by receipt of written notice from the insurer or the Contractor at least thirty (30) days prior to material modification or cancellation of any policy listed on the Certificate.

Bidders are referred to Article GC-38 of the General Conditions for additional insurance information.

- b. Notice of Claim Reduction of Policy Limits: The Contractor, upon receipt of notice of any claim in connection with the agreement, shall promptly notify the

City, providing full details thereof, including an estimate of the amount of loss or liability.

The Contractor shall monitor and promptly notify the City of any reduction in limits of protection afforded under any policy listed in the Certificate (or otherwise required by the contract documents) if the Contractor's limits of protection shall have been impaired or reduced to such extent that the limits fall below the minimum amounts required herein. The Contractor shall promptly reinstate the original limits of liability required hereunder and shall furnish evidence thereof to the City.

c. Commercial General Liability:

Limits –

General Aggregate:	\$2,000,000
Products / Completed Operations Aggregate:	\$2,000,000
Personal & Advertising Injury:	\$1,000,000
Each Occurrence:	\$1,000,000

Policy MUST include the following conditions:

1. Pollution Liability (Applicable only to contracts involving pollutants such as asbestos & lead abatement, sludge or other waste abatement, etc.)
2. **NAME CITY OF MISSION AS “ADDITIONAL INSURED”**

d. Automobile Liability: Policy shall protect the Contractor against claims for bodily injury and/or property damage arising from the ownership or use of any owned, hired and/or non-owned vehicle.

Limits (Same as Commercial General Liability) -

Combined Single Limits, Bodily Injury and Property Damage - Each Accident:

Policy MUST include the following condition:

NAME CITY OF MISSION AS “ADDITIONAL INSURED”

e. Umbrella Liability: The Umbrella / Excess Liability must be at least as broad as the underlying general liability and automobile liability policies.

Limits –

Each Occurrence	\$1,000,000
General Aggregate	\$1,000,000

f. Workers' Compensation: This insurance shall protect the Contractor against all claims under applicable state workers' compensation laws. The Contractor shall also be protected against claims for injury, disease or death of employees which, for any reason, may not fall within the provisions of workers' compensation law. The policy limits shall not be less than the following:

Workers' Compensation:	Statutory
Employer's Liability:	

Bodily Injury by Accident	\$100,000 each accident
Bodily Injury by Disease	\$500,000 policy limit
Bodily Injury by Disease	\$100,000 each employee

g. Owner's Protective Liability: The Contractor shall take out, pay for and deliver to the City, an Owner's Protective Liability insurance policy written on an occurrence basis and naming the City as named insured. The policy shall be maintained during the life of the agreement. Limits of protection shall be at least **\$1,000,000** Combined Single Limits, Bodily Injury and Property Damage, and shall contain no exclusion relative to any function performed by the City or its employees and agents in connection with the project.

h. Industry Ratings: The City will only accept coverage from an insurance carrier who offers proof that it:

1. Is authorized to do business in the State of Kansas;
2. Carries a Best's policy holder rating of A- or better; and
3. Carries at least a Class VIII financial rating, **or**
4. Is a company mutually agreed upon by the City and Contractor.

i. Subcontractors' Insurance: If a part of the Contract is to be sublet, the Contractor shall either:

1. Cover all subcontractors in its insurance policies, **or**
2. Require each subcontractor not so covered to secure insurance which will protect subcontractor against all applicable hazards or risks of loss as and in the minimum amounts designated.

Whichever option is chosen, contractor shall indemnify and hold harmless the City as to any and all damages, claims or losses, including attorney's fees, arising out of the acts or omissions of its subcontractors.

j. Railroad Protective Liability: Additional requirement applicable when working on railroad property.

Named Insured: Applicable Railroad
Limits – Bodily Injury & Property Damage: Per Railroad Requirements

k. Aircraft Liability: Additional requirement applicable for aerial photograph or contract involving any use of aircraft.

Limits- Single Limit Bodily Injury; Including Passengers; and Property
Damage:
 \$1,000,000 Each Occurrence

Coverage must include all Owned, Hired and Non-Owned Aircraft.

Policy **MUST** include the following condition:

NAME CITY OF MISSION AS "ADDITIONAL INSURED" ON THE HIRED AND NON-OWNED AIRCRAFT LIABILITY.

- I. Contractor Property Insurance ("Builder's Risk"): [Additional requirement when constructing a building.] Unless otherwise provided in the contract documents, Contractor shall procure and maintain property insurance from insurance companies authorized to do business in the State of Kansas upon the entire project to the full insurable value of the project, including professional fees, overtime premiums and all other expenses incurred to replace or repair the insured property. The property insurance obtained by Contractor shall include as additional insured's the interests of City, Contractor, design consultants, subcontractor and sub-subcontractors, and shall insure against the risk of direct physical loss including but not limited to fire and extended coverage, theft, vandalism, malicious mischief, collapse, flood, earthquake, debris removal and other perils or causes of loss as called for in the contract documents. The property insurance shall include physical loss or damage to the work, including materials and equipment in transit, at the site or at another location as may be indicated in Contractor's application for payment and approved by City. All deductibles are the responsibility of the Contractor.
 1. Unless the contract documents provide otherwise, Contractor shall procure and maintain boiler and machinery insurance that will include the interests of City, Contractor, design consultants, subcontractors and sub-subcontractors.
 2. Prior to commencing any work, Contractor shall provide City with certificates evidencing that (1) all Contractor's insurance obligations required by the contract documents are in full force and in effect and will remain in effect until Contractor has completed all of the work and has received final payment from City and (2) no insurance coverage will be canceled, renewal refused, or materially changed unless at least thirty (30) days prior written notice is given to City. Contractor's property insurance shall not lapse or be canceled if City occupies a portion of the work. Contractor shall provide City with the necessary endorsements from the insurance company prior to occupying a portion of the work.
 3. Any loss covered under Contractor's property insurance shall be adjusted with City and Contractor and made payable to both of them as trustees for the insured's as their interests may appear, subject to any applicable mortgage clause. All insurance proceeds received as a result of any loss will be placed in a separate account and distributed in accordance with such agreement as the interested parties may reach. Any disagreement concerning the distribution of any proceeds will be resolved in accordance with Article II of the Agreement.
 4. City and Contractor waive against each other and City's separate contractors, design consultants, subcontractors, agents and employees of each and all of them, all damages covered by property insurance provided herein, except such rights as they may have to the proceeds of such insurance. Contractor and City shall, where appropriate, require similar waivers of subrogation from City's separate contractors, design consultants and subcontractors and shall require each of them to include similar waivers in their contracts.

IB-9. BID SECURITY: Each Bid shall be accompanied by a bid bond or a certified cashier's check on an acceptable bank, made payable, without condition, to the City of Mission,

Kansas, (hereinafter "City") in an amount of not less than five percent (5%) of the total Bid. In addition to other legal remedies, the amount of said bid security may be retained by and forfeited to the City as liquidated damages if such Bid is accepted and the Successful Bidder fails to enter into an agreement in the form prescribed, within the time specified in the notice of award by the City; provided, however, that the City shall not necessarily be limited in protecting its legal rights to enforcement of its rights under the bid security. Deposits will be returned to unsuccessful Bidders, with the exception of the second qualifying Bidder, at such time as their Bids are rejected. The Bid deposit of the Successful Bidder and the second qualifying Bidder will be returned when satisfactory insurance certificates, performance bond and statutory or labor and material payment bond in an amount equal to 100% of the agreement and other documents required by the General Conditions have been furnished and the contract documents have been executed.

IB-10. TAXES: It is the intent of the City to supply the Contractor with a Project Exemption Certificate for use in purchasing materials and supplies used on the project. The Contractor shall, in preparing its Bid, omit from its computed costs all sales and compensation taxes. Upon issuance of a Kansas tax exemption number, two (2) copies of the Project Exemption Certificate (Form PR-74a) will be forwarded to the Contractor. Upon completion of the project, the City will provide the State of Kansas with the project completion date and the State will issue a Project Completion Certification. This will be forwarded to the Contractor who must sign and return it to the City. All invoices must be retained by the Contractor for a period of five (5) years and are subject to audit by the Kansas Department of Revenue. Final payment will not be made to the Contractor until the City has received the Project Completion Certification from the Contractor along with a Consent of Surety Company to Final Payment.

IB-11. LIQUIDATED DAMAGES: In case of failure on the part of the Contractor to effect completion within the time specified, the City shall have the right to deduct from the total compensation otherwise due the Contractor as liquidated damages based on the full Bid price of the agreement, fixed and agreed to in advance, according to the following schedule:

<u>Contract Amount</u>		<u>Liquidated Damages</u>
\$0	to \$50,000	\$250.00
\$50,000	to \$100,000	\$400.00
\$100,000	to \$500,000	\$800.00
\$500,000	to \$1,000,000	\$1,000.00
\$1,000,000	to \$2,000,000	\$1,750.00
\$2,000,000	to \$5,000,000	\$2,500.00
\$5,000,000	to \$10,000,000	\$3,500.00
\$10,000,000	to \$20,000,000	\$5,500.00
\$20,000,000	and up	\$6,000.00

for each twenty-four (24) hour calendar day, including Sundays and holidays, the work remains incomplete over the specified completion time. **(THE CITY RESERVES THE RIGHT TO ADJUST THE SCHEDULE OF LIQUIDATED DAMAGES, PRIOR TO ADVERTISING FOR BIDS, BASED ON THE SCOPE AND URGENCY OF THE PROJECT.)**

In the event moneys being retained by the City shall not be sufficient to cover the amount of any liquidated damages, City may sue for and recover compensation for damages for nonperformance of the contract at the time stipulated herein and provided for.

IB-12. MODIFICATION OR WITHDRAWAL OF BIDS: Bids may be modified or withdrawn by written request of the Bidder received in the office of the City Clerk, prior to the time and date for Bid opening. No Bidder may withdraw its Bid for a period of thirty (30) days from the date set for the opening thereof.

IB-13. ACCEPTANCE AND REJECTION OF BIDS AND AWARD OF CONTRACT: The contract will be awarded to the lowest and best, responsible Bidder as determined by the City.

The City reserves the right to reject any and all Bids; to waive any and all irregularities and informalities; to negotiate contract terms with the Successful Bidder; and the right to disregard all nonconforming, non-responsive or conditional Bids.

In evaluating Bids, the City may consider the qualification of Bidders, whether or not the Bids comply with the prescribed requirements, and alternates and Unit Prices if requested in the Bid forms. The City reserves the right to reject the Bid of any Bidder who does not pass the evaluation to the City's satisfaction.

IB-14. BONDS: The Contractor to whom the work is awarded will be required to furnish a Performance Bond, Maintenance Bond, and a Statutory or Labor and Material Payment Bond in the forms hereinafter provided in an amount equal to 100 percent (100%) of the amount of the contract to be awarded in each case in addition to any other bonds as may be required by the contract documents. With each bond there shall be filed with the City one copy of "Power of Attorney" certified to include the date of the bonds.

IB-15. INDEMNIFICATION: The Contractor shall be required to indemnify and hold the City harmless as set forth in Article GC-33 of the General Conditions.

IB-16. BID PREFERENCE: Existing State law (K.S.A. 75-3740a) requires that, to the extent permitted by federal law and regulations, the City, when letting contracts for bids, must require any Successful Bidder-Contractor domiciled outside the state of Kansas to submit a Bid the same percent less than the lowest bid submitted by a responsible Kansas contractor as would be required of such Kansas domiciled contractor to succeed over the bidding Contractor domiciled outside Kansas on a like contract let in the foreign Bidder's domiciliary state. All Bids are received on this condition, and if it is determined by the City that the apparent lowest and best Bidder is a foreign domiciled contractor, such contractor shall be awarded the Contract only if such Contractor's Bid complies with this state law requirement.

All Bidders domiciled outside of the State of Kansas may be requested to furnish the City with a copy of their state's preferential bidding statutes, if any.

IB-17. NON-DISCRIMINATION, AFFIRMATIVE ACTION AND SEXUAL HARASSMENT: The Contractor shall comply with Article GC-68 of the General Conditions.

- IB-18. APPOINTMENT OF SERVICE AGENT: Kansas Statutes Annotated 16-113 requires that non-resident Contractors appoint an agent for the service of process in Kansas. The executed appointment must then be filed with the Secretary of State, Topeka, Kansas. Any Successful Bidder-Contractor domiciled outside the State of Kansas must comply with these statutory requirements.
- IB-19. SUBCONTRACTING: As provided in Article GC-36, the Contractor may utilize the services of subcontractors on those parts of the work which, under normal contracting practices, are performed by subcontractors.
- IB-20. CONFLICT OF INTEREST: 31 USCS Section 1352 requires all subgrantees, Contractors, subcontractors and consultants who receive federal funds via the City to certify that they will not use federal funds to pay any person for influencing or attempting to influence a federal agency or Congress in connection with the award of any federal contract, grant, loan or cooperative agreements.

In addition, contract applicants, recipients and subrecipients must file a form disclosing any expenditures they make for lobbying out of non-federal funds during the agreement period. Necessary forms are available from the City Engineer and should be returned to the City with other contract documents. It is the responsibility of the general Contractor to obtain executed forms from any subcontractors who fall within the provisions of the Code and to provide the City with the same.

BID

2017 STORM SEWER POINT REPAIRS, CONTRACT 1

TO: CITY OF MISSION,
JOHNSON COUNTY, KANSAS

Neither the City nor Consultant shall be responsible for the accuracy, completeness, or sufficiency of any bid documents obtained from any source other than the source indicated in the Notice to Bidders. Obtaining copies of plans, specifications, bid documents and other contract documents from any other source(s) may result in obtaining incomplete and inaccurate information. Obtaining these documents from any source other than directly from the source listed in the Notice to Bidders may also result in failure to receive any addenda, corrections, or other revisions to these documents that may be issued.

The undersigned bidder hereby proposes to mobilize and furnish all materials, supplies, transportation, tools, equipment and plant, perform all necessary labor and construct, install and complete all work stipulated in, required by, and in conformity with the proposed contract documents (including all documents referred to therein) and any and all addenda thereto, for and in consideration of prices as follows:

ITEM NO.	ITEM DESCRIPTION	UNIT	QUANTITY	UNIT COST \$	COST \$
1	Base Bid - 5820 W 61st Terrace	1	L.S.		
2	Base Bid - 6500 W 51st Street	1	L.S.		
3	15" RCP with O-Ring Gaskets and Bedding	33	L.F.		
4	18" RCP with O-Ring Gaskets and Bedding	331	L.F.		
5	24" RCP with O-Ring Gaskets and Bedding	168	L.F.		
6	4' Diameter Precast Storm Manhole	2	Ea.		
7	4'x3' Precast Curb Inlet	4	Ea.		
8	Trench Backfill and Restoration, Unpaved Area	378	L.F.		
9	Trench Backfill and Restoration, Paved Area	148	L.F.		

TOTAL BID \$ _____

1. The undersigned further agrees to begin upon the date stated in the Notice to Proceed and to complete the work, if this bid is accepted, no later than June 30, 2017 subject to the conditions set forth in paragraph SC-19, CONSTRUCTION TIMELINE AND LIMITATIONS, of the Project Special Conditions.

The undersigned also declares that it understands that if not preset by the City the time to begin construction and to complete the work will be one factor considered in determining the lowest and best responsible bidder.

The undersigned also declares that he/she understands that liquidated damages based on the full bid price of the contract shall be assessed against Contractor, as stipulated liquidated damages and not as a penalty, in an amount as set forth in paragraph GC-46 of the General Conditions for each and every calendar day the work remains incomplete over the specified completion time(s).

2. In submitting this bid, the undersigned declares that it is of lawful age and executed the accompanying bid on behalf of the bidder therein named, and that it had lawful authority so to do. The undersigned further declares that it has not directly or indirectly entered into any agreement, expressed or implied, with any bidder or bidders, having for its object the controlling of the price or amount of such bid or any bids, the limiting of the bid or bidders, the parceling or farming out to any bidder or bidders, or other persons, of any part of the contract or any part of the subject matter of the bid or bids or of the profits thereof, and that it has not and will not divulge the sealed bid to any person whomsoever, except those having a partnership or other financial interest with bidder in said bid or bids, until after sealed bid or bids are opened.
3. The undersigned further declares that it has carefully examined the Notice to Bidders, Instructions to Bidders and other contract documents, and that it has inspected the actual location of the work, together with the local sources of supply, and has satisfied itself as to all conditions and quantities, and understands that in signing this Bid it waives all right to plead any misunderstanding regarding the same.
4. The undersigned hereby agrees to furnish the required bonds and insurance certificates and execute an agreement within ten (10) calendar days from and after notice of the award of the contract, and failure of the bidder to do so shall constitute a default, and the City may thereafter take such steps to protect its legal rights as it deems in its best interest, including, but not limited to, enforcement of its rights as to bid security.
5. It is understood that the City will pay in a prompt and timely manner pay estimates when submitted and approved by the Architect/Engineer and further approved by the City staff coordinator for the project, all as provided in the contract documents.
6. Undersigned acknowledges receipt of the Plans and Specifications for the project including the following addenda (complete) _____
_____.

Enclosed is a certified check, cashier's check or bid bond in the amount of

_____ DOLLARS (\$_____) which the undersigned agrees is subject to being forfeited to and becoming the property of the City as liquidated damages and not as a penalty, together with other legal remedies the City may choose to invoke, all as set forth in the Instructions to Bidders Section IB-9, should this Bid be accepted and the contract be awarded to this bidder and it should fail to enter into an agreement in the form prescribed and to furnish the required insurance, bonds and other required documents within ten (10) calendar days as above stipulated, otherwise the bid security shall be returned to the undersigned upon signing of the agreement and delivery of the approved bonds and other required documents to the City of Mission, Kansas.

DATED in _____ this _____ day of _____, 2015.

(SEAL)

Contractor

Signature

Printed Name

Title

Street Address or P.O. Box

City, State, Zip

Telephone Number

Fax Number

CITY OF MISSION, KANSAS

AGREEMENT BETWEEN
CITY OF MISSION, KANSAS
AND CONTRACTOR

2017 STORM SEWER POINT REPAIRS, CONTRACT 1

THIS AGREEMENT is made and entered into this _____ day of _____, 20____, by and between the City of Mission, Kansas, hereinafter the "City", and _____, hereinafter the "Contractor".

WITNESSETH:

WHEREAS, the City has caused to be prepared, in accordance with the law, Notice to Bidders, Instructions to Bidders, Bid, this Agreement, General Conditions, Project Special Provisions, Plans, Specifications and other Contract Documents, as defined in the General Conditions, for the work herein described, and has approved and adopted these said Contract Documents and has caused to be published, in the manner and for the time required by law, an advertisement inviting sealed Bids for furnishing construction materials, labor, tools, equipment and transportation necessary for, and in connection with, the construction of public improvements in accordance with the terms of this Agreement; and

WHEREAS, the Contractor, in response to the advertisement, has submitted to the City, in the manner and at the time specified, a sealed Bid in accordance with the terms of this Agreement; and

WHEREAS, the City, in the manner prescribed by law, has publicly opened, examined and canvassed the Bids submitted, and as a result of this canvass has, in accordance with the law, determined and declared the Contractor to be the lowest and best responsible bidder for the construction of the public improvements, and has duly awarded to the Contractor a contract therefor upon the terms and conditions set forth in this Agreement and for the sum or sums named in the Bid attached to and made a part of this Agreement.

NOW, THEREFORE, in consideration of the compensation to be paid the Contractor, and of the mutual agreements herein contained, the parties hereto have agreed, and hereby agree, the City for itself and its successors, and the Contractor for itself, himself/herself or themselves, its, his/her or their successors and assigns, or its, his/her or their executors and administrators, as follows:

ARTICLE I. The Contractor will furnish at its own cost and expense all labor, tools, equipment, materials and transportation required to construct and complete the work as designated, described and required by the Contract Documents, to wit: **2017 STORM SEWER POINT REPAIRS, CONTRACT 1** all in accordance with the Notice to Bidders, Instructions to Bidders, Bid, this Agreement, General Conditions, Project Special Provisions, Plans, Specifications and other Contract Documents as defined in paragraph GC-1 of the General Conditions of the Contract for Construction, on file with the City Clerk of Mission, Kansas, all of which Contract Documents form the Contract, and are as fully a part hereof as if repeated verbatim herein; all work to be done in a good, substantial and workmanlike manner to the entire satisfaction of the City, and in accordance with the laws of the City, the State of Kansas and the United States of

America. All terms used herein shall have the meanings ascribed to them in the General Conditions unless otherwise specified.

ARTICLE II. The City shall pay to the Contractor for the performance of the work embraced in this Contract, and the Contractor will accept in full compensation therefor, the sum of _____

DOLLARS (\$ _____) (subject to adjustment as provided by the Contract Documents) for all work covered by and included in the Contract award and designated in the foregoing Article I, payment thereof to be made in cash or its equivalent and in the manner provided in the Contract Documents.

ARTICLE III. The Contractor shall commence work upon the date stated in the Notice to Proceed, and will complete all work covered by this Contract no later than September 15, 2017 subject to the conditions set forth in paragraph SC-19, CONSTRUCTION TIMELINE AND LIMITATIONS, of the Project Special Conditions. Liquidated damages based on the full bid price of the Contract shall be assessed against Contractor, as stipulated liquidated damages and not as a penalty, in an amount as set forth in paragraph GC-46 of the General Conditions for each and every calendar day the work remains incomplete over the specified completion time(s) stated above.

ARTICLE IV. The Contractor shall not subcontract, sell, transfer, assign or otherwise dispose of the Contract or any portion thereof without previous written consent of the City. In case such consent is given, the Contractor shall be permitted to subcontract a portion thereof, but shall self-perform not less than forty percent (40%) of the total Contract Price based upon the unit prices within the Bid submitted to the City by the Contractor. No subcontracts, or other transfer of Contract, shall release the Contractor of its liability under the Contract and Bonds applicable thereto.

ARTICLE V. Contractor specifically acknowledges and confirms that: (1) it has visited the site, made all inspections it deems appropriate and has read and fully understands the Contract Documents, including all obligations and responsibilities undertaken by it as specified herein and in the other Contract Documents and knowingly accepts same; (2) it has furnished copies of all Contract Documents to its insurance carrier(s) and its surety(ies); and (3) its insurance carrier(s) and surety(ies) agree to be bound as specified herein, in the Contract Documents and in the insurance policy(ies) and bonds as to liability and surety coverage.

ARTICLE VI. It is specifically agreed between the parties executing this Agreement that the Contract Documents are not intended to create any third party beneficiary relationship nor to authorize anyone not a party to this Agreement to maintain a suit for personal injuries or property damage pursuant to the terms or provisions of this Agreement. The duties, obligations and responsibilities of the parties to this Agreement with respect to third parties shall remain as imposed by law.

ARTICLE VII. This Agreement, together with the other Contract Documents, constitutes the entire agreement between the parties and supersedes all prior agreements, whether oral or written, covering the same subject matter. This Agreement may not be modified or amended except as provided herein or in the other Contract Documents.

ARTICLE VIII. This Agreement is entered into, under and pursuant to, and is to be construed and enforceable in accordance with, the laws of the State of Kansas.

ARTICLE IX. Should any provision of this Agreement or the other Contract Documents be determined to be void, invalid, unenforceable or illegal for whatever reason, such provision(s)

shall be null and void; provided, however, that the remaining provisions of this Agreement and/or the other Contract Documents shall be unaffected thereby and shall continue to be valid and enforceable.

IN WITNESS WHEREOF, the City of Mission, Kansas, has caused this Agreement to be executed on its behalf, thereunto duly authorized, and the said Contractor has executed three (3) counterparts of this Contract in the prescribed form and manner, the day and year first above written.

CITY OF MISSION, KANSAS

ATTEST:

By _____
Steve Schowengerdt
Mayor

Martha Sumrall
City Clerk

APPROVED AS TO FORM:

David Martin
City Attorney

Contractor

(SEAL)

By _____
Title _____ President _____

(If the Contract is not executed by the president of the corporation or general partner of the partnership, please provide documentation which authorizes the signatory to bind the corporation or partnership. If a corporation, Contractor shall furnish City a current certificate of good standing, dated within ten (10) days of the date of this Contract.)

CITY OF MISSION, KANSAS

PERFORMANCE BOND

KNOW ALL MEN BY THESE PRESENTS, that we, the undersigned _____, of _____ as principal, hereinafter referred to as the "Contractor," and _____, a corporation organized under the laws of the State of _____ and authorized to transact business in the State of Kansas, as surety, are held and firmly bound unto the City of Mission, Kansas, hereinafter referred to as "City," in the penal sum of _____ Dollars (\$ _____), lawful money of the United States of America, for the payment of which sum well and truly to be made we bind ourselves, and our heirs, executors, administrators, successors and assigns, jointly and severally by these presents:

THE CONDITION OF THE FOREGOING OBLIGATION IS SUCH THAT:

WHEREAS, the above bonded Contractor, has on the ____ day of _____, 20____, executed a written Agreement with the aforesaid City for furnishing in a good, substantial and workmanlike manner all construction, labor, materials, equipment, tools, transportation, superintendence and other facilities and accessories for **2017 STORM SEWER POINT REPAIRS, CONTRACT 1** designated, defined and described in the Agreement and in accordance with the Contract Documents to include the General Conditions, Project Special Provisions, Specifications, Plans and other Contract Documents therefor; a copy of the Agreement being attached hereto and made a part hereof.

NOW, THEREFORE, if said Contractor shall in all particulars promptly and faithfully perform each and every covenant, condition, and part of the Agreement, and the General Conditions, Project Special Provisions, Specifications, Plans and other Contract Documents thereto attached or by reference made a part thereof, according to the true intent and meaning in each case, upon written acceptance by the City of the improvement herein described in substantial compliance with the Contract Documents and upon the effective date of the Maintenance Bond for the improvement then this obligation shall be and become null and void.

PROVIDED, that said Surety, for value received, hereby stipulates and agrees that no change, extension of time, alteration or addition to the terms of the Agreement or the Work to be performed thereunder or the General Conditions, Project Special Provisions, Specifications, Plans and other Contract Documents accompanying same shall in any way affect its obligation on this bond, and it does hereby waive notice of any such change, extension of time, alteration or addition to the terms of the Agreement or to the Work or to the Specifications, Plans and other Contract Documents.

PROVIDED, FURTHER, that it is expressly agreed that the bond shall be deemed amended automatically and immediately, without formal and separate amendments hereto, upon amendment to the Agreement not increasing the contract price more than 50 percent, so as to bind the Contractor and the Surety to the full and faithful performance of the Agreement so amended. The term "amendment," wherever used in this bond, and whether referring to this bond or the Agreement, shall include any alteration, addition, extension, or modification of any character whatsoever.

Whenever Contractor is declared by City to be in default under the Contract Documents, the Surety may promptly remedy the default or shall within fourteen (14) days from the date of notice from the City:

1. Commence completing the Work of the Agreement in accordance with its terms and conditions. However, Surety may not use the defaulting Contractor, or any legal reformation of the defaulting Contractor, to complete the Work and the Surety may not use any of the subcontractors of the defaulting Contractor to complete the Work without the written consent of the City; or
2. Commence the process of obtaining a bid or bids for completing the Work of the Agreement in accordance with its terms and conditions, and upon determination by the City and the surety jointly of the lowest and best responsive, responsible bidder, arrange for an Agreement between such bidder and the City, and make available as work progresses sufficient funds to pay the cost of completion less the balance of the Contract Price, including other costs and damages for which the surety may be liable hereunder, which sum shall not exceed the amount set forth in the first paragraph hereof. The term "balance of the Contract Price," as used in this paragraph, shall mean the total amount payable by City to Contractor under the Agreement and any amendments thereto, less the amount properly paid by City to Contractor. No right of action shall accrue on this bond to or for the use of any person or corporation other than the City or successors of the City.

IN TESTIMONY WHEREOF, said Contractor has hereunto set his/her hand, and said surety has caused these presents to be executed in its name; and its corporate seal to be hereunto affixed by its attorney-in-fact duly authorized thereunto so to do at _____, _____ on this, the _____ day of _____, 20_____.

Contractor/Principal

ATTEST:

By _____(SEAL)

Secretary

Title

Surety Company

By _____(SEAL)
Attorney-in-Fact

NOTE:

1. Date of bond must not be prior to date of contract.
2. If Contractor is partnership, all partners should execute bond.
3. Surety companies executing bonds must appear on the Treasury Department's most current list (Circular 570 as amended) and be authorized to transact business in the state of Kansas.
4. Accompany this bond with Attorney-in-Fact's Authority from the surety company certified to include the date of the bond.

CITY OF MISSION, KANSAS

MAINTENANCE BOND

KNOW ALL MEN BY THESE PRESENTS, that we, the undersigned _____
_____ of _____
as principal, hereinafter referred to as the "Contractor," and _____
_____, hereinafter referred to as the "Surety",
a corporation organized under the laws of the State of _____ and authorized to
transact business in the State of Kansas, as surety, are held and firmly bound unto the City of
Mission, Kansas, hereinafter referred to as "City," in the penal sum of _____
_____ Dollars (\$_____), lawful
money of the United States of America, for the payment of which sum well and truly to be made
we bind ourselves, and our heirs, executors, administrators, successors and assigns, jointly and
severally by these presents:

THE CONDITION OF THE FOREGOING OBLIGATION IS SUCH THAT:

WHEREAS, the above bonded Contractor, has on the _____ day of _____,
20____, executed a written Agreement with the aforesaid City for furnishing in a good, substantial
and workmanlike manner all construction, labor, materials, equipment, tools, transportation,
superintendence and other facilities and accessories for **2017 STORM SEWER POINT
REPAIRS, CONTRACT 1**, hereinafter referred to as the "Improvement", designated, defined
and described in the Agreement and the Contract Documents, and in accordance with the
Specifications and Plans and other Contract Documents therefor; a copy of the Agreement
being attached hereto and made a part hereof.

NOW, THEREFORE, upon acceptance of the Improvement by the City in substantial
compliance with the Contract Documents, if said Improvement endures without defect or need
of repair or maintenance for a period of two (2) years from the date of final acceptance, then this
obligation shall be and become null and void.

If the Improvement requires repairs or maintenance within such two (2) year period then this
obligation shall remain in full force and effect and Contractor and the Surety shall be responsible
for the prompt payment of the penal sum to the City for such repairs and/or maintenance
including any incidental costs associated therewith, including but not limited to the costs of
consultants and/or engineering investigations, testing, analysis and any other costs incurred to
determine the cause of the defect and/or the necessary repair or maintenance and attorney fees
incurred in collection of this Maintenance Bond.

PROVIDED, that said Surety, for value received, hereby stipulates and agrees that no change,
extension of time, alteration or addition to the terms of the Agreement or the Work to be
performed thereunder or the Specifications, Plans and other Contract Documents
accompanying same shall in any way affect its obligation on this bond, and it does hereby waive
notice of any such change, extension of time, alteration or addition to the terms of the
Agreement or to the Work or to the Specifications, Plans and other Contract Documents.

PROVIDED, FURTHER, that it is expressly agreed that the bond shall be deemed amended
automatically and immediately, without formal and separate amendments hereto, upon
amendment to the Agreement not increasing the contract price more than 50 percent, so as to
bind the Contractor and the Surety to the full and faithful performance of the Agreement so
amended. The term "amendment," wherever used in this bond, and whether referring to this
bond or the Agreement, shall include any alteration, addition, extension, or modification of any
character whatsoever.

IN TESTIMONY WHEREOF, said Contractor has hereunto set his/her hand, and said surety has caused these presents to be executed in its name; and its corporate seal to be hereunto affixed by its attorney-in-fact duly authorized thereunto so to do at _____
_____ on this, the _____ day of _____, 20__.

Contractor/Principal

ATTEST:
(SEAL)

By _____
Print Name: _____

Title

Secretary

Surety Company

(SEAL)

By _____
Attorney-in-Fact

NOTE:

1. Date of bond must not be prior to date of contract.
2. If Contractor is partnership, all partners should execute bond.
3. Surety companies executing bonds must appear on the Treasury Department's most current list (Circular 570 as amended) and be authorized to transact business in the state of Kansas.
4. Accompany this bond with Attorney-in-Fact's Authority from the surety company certified to include the date of the bond.

CITY OF MISSION, KANSAS

STATUTORY BOND

2017 STORM SEWER POINT REPAIRS, CONTRACT 1

KNOW ALL MEN BY THESE PRESENTS, that we _____
_____ as Contractor and principal, and _____
_____ a corporation organized under the laws of the State of _____
_____ and authorized to transact business in the State of Kansas, as surety, are held and firmly bound
unto the State of Kansas, in the penal sum of _____
_____ Dollars (\$ _____) lawful money of the United States of
America, for the payment of which sum well and truly to be made, we bind ourselves, and our heirs,
executors, administrators, successors, and assigns, jointly and severally, firmly by these presents:

THE CONDITION OF THE FOREGOING OBLIGATION IS SUCH THAT:

WHEREAS, the said Contractor has on the ____ day of _____, 20____, entered into an
Agreement with the City of Mission, Kansas, a copy of which is attached hereto and incorporated herein
for furnishing all tools, equipment, materials, transportation and supplies, performing all labor, and
constructing public improvements described in the Agreement and the Contract Documents, all in
accordance with Provisions, Specifications, Plans and other Contract Documents on file in the office of
the City Clerk of the City of Mission, Kansas.

NOW, THEREFORE, if the Contractor or the subcontractors of the Contractor shall pay all indebtedness
incurred for supplies, materials, transportation or labor furnished, or equipment used or consumed in
connection with or in or about the construction or making of the improvements described in the
above-mentioned Contract Documents, then this obligation shall be void; otherwise, it shall remain in full
force and effect.

The said Surety, for value received, hereby stipulates and agrees that no change, extension of time,
alteration or addition to the terms of the Agreement and the Contract Documents to the work to be
performed thereunder, or the Provisions, Plans and Specifications accompanying the same, shall in any
way affect its obligation on this bond, and it does hereby waive notice of any such change, extension of
time alteration or addition to the terms of the Agreement, Contract Documents or to the Plans and
Specifications.

PROVIDED, that it is expressly agreed that this bond shall be deemed amended automatically and
immediately, without formal and separate amendments hereto, upon amendment to the Agreement not
increasing the contract price more than 50 percent, so as to bind the Contractor and the Surety to the full
and faithful performance of the Agreement as so amended. The term "amendment," wherever used in
this bond and whether referring to this bond or the Agreement shall include any alteration, addition,
extension or modification of any character whatsoever.

The said Surety further agrees that any person to whom there is due any sum for labor furnished,
transportation, materials, equipment or supplies used or consumed in connection with or in or about the
construction of said public improvement, as hereinbefore stated or said person's assigns, may bring
action on this bond for the recovery of said indebtedness within six (6) months from the completion of said
public improvement.

IN TESTIMONY WHEREOF, the said Contractor has hereunto set his/her hand, and the said surety has caused these presents to be executed in its name, and its corporate seal to be hereunto affixed, by its attorney-in-fact duly authorized thereunto so to do, at _____ on this, the _____ day of _____, 20_____.

Contractor/Principal

ATTEST:

Secretary

By _____ (SEAL)

Title

Surety Company

By _____ (SEAL)
Attorney-in-Fact

NOTE:

1. A Statutory Bond is required only in connection with a Contract exceeding one hundred thousand dollars (\$100,000.00) in accordance with K.S.A. 60-1111 as amended.
2. Contractor shall be responsible for seeing to it that this Statutory Bond is filed with the Clerk of the District Court for Johnson County, Kansas.
3. Date on bond must not be prior to date of contract.
4. If Contractor is partnership, all partners should execute bond.
5. Surety companies executing bonds must appear on the Treasury Department's most current list (Circular 570 as amended) and be authorized to transact business in the state of Kansas.
6. Accompany this bond with Attorney-in-Fact's Authority from the surety company certified to include the date of the bond.

CITY OF MISSION, KANSAS

LABOR AND MATERIAL PAYMENT BOND

2017 STORM SEWER POINT REPAIRS, CONTRACT 1

KNOW ALL MEN BY THESE PRESENTS, that we _____ as Contractor and principal, and _____, a corporation organized under the laws of the State of _____ and authorized to transact business in the State of Kansas, as surety, are held and firmly bound unto the City of Mission, Kansas in the penal sum of _____ Dollars (\$_____) lawful money of the United States of America, for the payment of which sum well and truly to be made, we bind ourselves, and our heirs, executors, administrators, successors, and assigns, jointly and severally, firmly by these presents:

THE CONDITION OF THE FOREGOING OBLIGATION IS SUCH THAT:

WHEREAS, the said Contractor has on the _____ day of _____, 20____, entered into an Agreement with the City of Mission, Kansas, a copy of which is attached hereto and incorporated herein for furnishing all tools, equipment, materials, transportation and supplies, performing all labor, and constructing public improvements described in the Agreement and the Contract Documents, all in accordance with Provisions, Specifications, Plans and other Contract Documents on file in the office of the City Clerk of the City of Mission, Kansas.

NOW, THEREFORE, if the Contractor or the subcontractors of the Contractor shall pay all indebtedness incurred for supplies, materials, transportation or labor furnished, or equipment used or consumed in connection with or in or about the construction or making of the improvements described in the above-mentioned Contract Documents, then this obligation shall be void; otherwise, it shall remain in full force and effect.

The said Surety, for value received, hereby stipulates and agrees that no change, extension of time, alteration or addition to the terms of the Agreement and the Contract Documents to the work to be performed thereunder, or the Plans and Specifications accompanying the same, shall in any way affect its obligation on this bond, and it does hereby waive notice of any such change, extension of time, alteration or addition to the terms of the Agreement, Contract Documents or to the Plans and Specifications.

PROVIDED, that it is expressly agreed that this bond shall be deemed amended automatically and immediately, without formal and separate amendments hereto, upon amendment to the Agreement not increasing the contract price more than 50 percent, so as to bind the Contractor and the Surety to the full and faithful performance of the Agreement as so amended. The term "amendment," wherever used in this bond and whether referring to this bond or the Agreement shall include any alteration, addition, extension or modification of any character whatsoever.

IN TESTIMONY WHEREOF, the said Contractor has hereunto set his/her hand, and the said surety has caused these presents to be executed in its name, and its corporate seal to be hereunto affixed, by its attorney-in-fact duly authorized thereunto so to do, at _____ on this, the _____ day of _____, 20__.

Contractor/Principal

ATTEST:

Secretary

By _____
(SEAL)

Surety Company

By _____ (SEAL)
Attorney-in-Fact

NOTE:

1. A Labor and Material Payment Bond is required only in connection with a Contract which does not exceed one hundred thousand dollars (\$100,000.00).
2. Date on bond must not be prior to date of contract.
3. If Contractor is partnership, all partners should execute bond.
4. Surety companies executing bonds must appear on the Treasury Department's most current list (Circular 570 as amended) and be authorized to transact business in the state of Kansas.
5. Accompany this bond with Attorney-in-Fact's Authority from the surety company certified to include the date of the bond.

2017 STORM SEWER POINT REPAIRS, CONTRACT 1

TABLE OF CONTENTS
FOR
GENERAL CONDITIONS
(CITY'S STANDARD CONDITIONS FOR PUBLIC IMPROVEMENTS)

ARTICLE	SUBJECT	PAGE
GC-1	CONTRACT DOCUMENTS/CONTRACT FOR CONSTRUCTION	1
GC-2	DEFINITIONS.....	1
GC-3	DEFECTS IN CONTRACT DOCUMENTS.....	5
GC-4	BID	5
GC-5	COPIES OF THE CONTRACT	5
GC-6	SCOPE, NATURE AND INTENT OF PLANS AND SPECIFICATIONS	6
GC-7	BEGINNING, PROGRESS AND TIME OF COMPLETION OF WORK	6
GC-8	SHOP DRAWINGS.....	7
GC-9	CONTRACTOR'S RESPONSIBILITIES AS TO AMBIGUITIES.....	8
GC-10	CONCEALED CONDITIONS.....	8
GC-11	CONTRACTOR TO FURNISH STAKES AND HELP	8
GC-12	PRESERVATION OF MONUMENTS AND STAKES	8
GC-13	PERMITS AND NOTICES	9
GC-14	GENERAL ADMINISTRATION OF THE CONTRACT.....	9
GC-15	CONTRACTOR'S EMPLOYEES	10
GC-16	SAMPLES	10
GC-17	PROTECTION AND MAINTENANCE OF PUBLIC AND PRIVATE PROPERTY; LIABILITY.....	10
GC-18	WORK IN OR ACROSS STREET OR HIGHWAY RIGHT-OF-WAY	12
GC-19	MAINTENANCE OF TRAFFIC.....	12
GC-20	NOISE CONTROL.....	12
GC-21	DUST CONTROL	13
GC-22	INSPECTION OF WORK.....	13
GC-23	SUPERINTENDENCE AND SUPERVISION.....	14
GC-24	CONTRACTOR'S OFFICE AT SITE OF WORK	14
GC-25	CHANGES IN THE WORK	14
GC-26	DEDUCTIONS FOR UNCORRECTED WORK	17
GC-27	DELAYS AND EXTENSION OF TIME	17
GC-28	WORK STOPPAGES	18
GC-29	PATENT LIABILITY CLAUSE	18
GC-30	INDEPENDENT CONTRACTOR	18
GC-31	SEPARATE CONTRACTS	19
GC-32	RELATIONS WITH OTHER CONTRACTORS.....	19
GC-33	INDEMNITY.....	20
GC-34	PROTECTION OF PROPERTY/LIABILITY.....	21
GC-35	PROVISION FOR EMERGENCIES	21
GC-36	ASSIGNMENT AND SUBLETTING OF CONTRACT	21
GC-37	DISPUTE RESOLUTION.....	22
GC-38	INSURANCE	23
GC-39	AUTHORITY AND DUTY OF THE CONSULTING ENGINEER	24
GC-40	CORRECTION OF LABOR, ETC. - BEFORE FINAL PAYMENT	25
GC-41	CORRECTION OF LABOR, ETC. - AFTER FINAL PAYMENT	25
GC-42	RIGHT OF CITY TO TERMINATE CONTRACT	26

GC-43 CITY'S RIGHT TO DO WORK	27
GC-44 PAYMENTS	27
GC-45 PAYMENTS WITHHELD	28
GC-46 LIQUIDATED DAMAGES	29
GC-47 BONDS.....	29
GC-48 EASEMENTS AND RIGHTS-OF-WAY	30
GC-49 UTILITIES	30
GC-50 USE OF PREMISES.....	30
GC-51 ALLOWANCES.....	30
GC-52 CUTTING, PATCHING AND DIGGING.....	30
GC-53 CLEANING UP	31
GC-54 TEMPORARY FACILITIES.....	31
GC-55 SANITARY REGULATIONS AND WATER	31
GC-56 COMPLIANCE WITH LAWS.....	32
GC-57 UNFAVORABLE CONSTRUCTION CONDITIONS	32
GC-58 CONTRACTOR'S RISK	32
GC-59 SAFETY RULES.....	32
GC-60 WEEKENDS, HOLIDAY AND NIGHT WORK	33
GC-61 APPROVAL OF EQUALS.....	33
GC-62 TEST OF MATERIALS OFFERED BY CONTRACTOR.....	33
GC-63 TESTING OF COMPLETED WORK	34
GC-64 BORROW AND WASTE AREAS	34
GC-65 PARKING AREAS, DRIVES AND WALKS	34
GC-66 STREET SIGNS AND TRAFFIC AIDS.....	344
GC-67 PLACING WORK IN SERVICE/PARTIAL UTILIZATION	34
GC-68 NON-DISCRIMINATION/OTHER LAWS.....	34
GC-69 FEDERAL LOBBYING ACTIVITIES.....	35
GC-70 RECORDS	36
GC-71 TITLES, SUBHEADS AND CAPITALIZATION.....	36
GC-72 NO WAIVER OF RIGHTS.....	36
GC-73 SEVERABILITY	36
GC-74 GOVERNING LAW	36
GC-75 VENUE	36

GENERAL CONDITIONS
OF THE CONTRACT FOR CONSTRUCTION

GC-1 CONTRACT DOCUMENTS/CONTRACT FOR CONSTRUCTION

The Contract Documents are complementary, and what is called for by any one shall be as binding as if called for by all. The intention of the Contract Documents is to include all construction, labor, materials, tools, equipment and transportation necessary for the workmanlike construction of the Project in accordance with the Contract Documents.

The Contract Documents shall consist of (but not necessarily be limited to) the Agreement between the City and Contractor (sometimes referred to herein as the "Agreement"), these General Conditions, the Project Special Provisions, the Plans, the Specifications, all addenda issued prior to and all modifications issued after execution of the Contract (modifications consisting of written amendments to the Contract signed by both parties, Change Orders, written interpretations issued by the Consulting Engineer, written orders for minor changes in the Work issued by the Consulting Engineer and changes in the Work identified in Article GC-25), drawings and data which may be furnished by the Contractor and approved by the City, additional drawings which may be furnished by the Architect/Engineer which the Consulting Engineer deems necessary to make clear the intent of the Contract Documents (and, in particular, the Specifications), and the Bidding Documents. It is understood that the Work shall be carried out and the Project shall be constructed fully in accordance with the Contract Documents.

It is expressly understood and agreed that the bound volume of Contract Documents, any plans, schedules and other drawings herein referred to, and data which may be furnished by the Engineer as are necessary to make clear the intent of the Specifications and Plans, are each and all included in this Contract and the Work shall be done fully in accordance therewith.

If there is any conflict or discrepancy between the Agreement between the City and Contractor and these General Conditions or between the Agreement between City and Contractor and any other of the Contract Documents, the Agreement between City and Contractor shall prevail. If there is any discrepancy between the General Conditions and any other Contract Documents other than the Agreement between City and Contractor, the General Conditions shall prevail, unless such discrepancy is between the General Conditions and the Project Special Provisions, if any, in which case the Project Special Provisions shall prevail. The Contract Documents supersede all previous agreements and understandings between the parties, which previous agreements and understandings are of no further force and effect.

The Contract Documents as enumerated herein form the Contract for construction. The Contract may not be amended or modified except by a modification as hereinabove defined. These Contract Documents do not, nor shall they be construed to, create any contractual relationship of any kind between the City and any Subcontractor or remote tier Subcontractor.

All time limits stated in the Contract Documents are of the essence of the Contract.

GC-2 DEFINITIONS

Whenever any word or expression defined herein, or pronoun used in its stead, occurs in these Contract Documents, it shall have and is mutually understood to have the meaning herein given. Work described in words which so applied have a well-known technical or trade meaning shall be held to refer to such recognized standards.

1. "Bid" shall mean the offer or proposal of the Bidder submitted on the prescribed form setting forth the prices for the Work to be performed (and the City reserves the right to reject any and all bids).

2. "Bidder" shall mean any individual, partnership, corporation, association or other entity submitting a Bid for the Work.

3. "Bidding Documents" shall mean all documents related to a Bidder's submitting a Bid, including, but not limited to, the advertisement for Bids, if applicable, Instructions to Bidders, the Bid form, other sample bidding and contract forms and the proposed Contract Documents, including any addenda issued prior to receipt of Bids. At the City's option, Bidders may be required to complete and submit a prequalification statement.

4. "Bonds" shall mean the Bid, Performance, Maintenance, and Statutory or Labor and Material Payment Bond, together with such other instruments of security as may be required by the Contract Documents.

5. "Change Order" is a written order issued after the Agreement is executed by which the City, the Consulting Engineer and the Contractor agree to construct additional items of work, to modify the Contract Time, or, in lump sum contracts, to change the character and scope of Work shown on the Contract Plans, or as otherwise provided in Article GC-25. Change Orders must be signed by the City and the Contractor to be binding.

6. "City" shall mean the City of Mission, Kansas.

7. "Consultant" or "Consulting Engineer" shall mean the individual, firm or entity designated in the Contract Documents which has been employed by the City for the performance of professional engineering services in connection with the Project; or shall mean the City if the City acts as its own Engineer.

8. "Contract" and "Contract Documents" shall have the meaning ascribed to them in Article GC-1, such terms sometimes being used interchangeably.

9. "Contract Price" shall be the amount identified in the Agreement between City and Contractor as the total amount due Contractor for total completion of the Work as per the Contract Documents. Where the Contract provides that all or a part of the Work is to be Unit Price Work the Contract Price shall initially be deemed to include for all Unit Price Work an amount equal to the sum of the established unit prices for each separately identified item of Unit Price Work multiplied by the estimated quantity of each item required for the Work. It is understood and agreed that estimated quantities of items for Unit Price Work are not guaranteed and are solely for the purpose of comparison of bids and determining an initial Contract Price. Determinations of actual quantities and classifications of Unit Price Work shall be made by the Consulting Engineer. Each unit price shall be deemed to include Contractor's overhead and profit for each separately identified item.

10. "Contract Time" shall be the number of calendar days stated in the Contract Documents for the completion of the Work or shall be a date certain if so designated in the Contract Documents.

11. "Contractor" shall mean the entity entering into the Contract for the performance of the Work covered by this Contract, together with its duly authorized agents or legal representatives. (For purposes of indemnification, see GC-33 for definition of "Contractor".)

12. "Defective Work" shall mean Work which is unsatisfactory, faulty or deficient, or not in conformity with the Contract Documents. It shall also include Work damaged prior to approval of final payment unless responsibility for such damage shall have been expressly assumed by the City at substantial completion.

13. "Effective Date of the Agreement" shall mean the date indicated in the Agreement on which it becomes effective, but, if no such date is indicated, it shall mean the date on which the Agreement is signed and delivered by the City to the Contractor. For this purpose, delivery shall be accomplished by either hand-delivery to the Contractor or placing a copy in the mail, first class, postage prepaid.

14. "Field Order" shall mean a written order issued by the Consulting Engineer which orders minor changes in the Work in accordance with Article GC-25 but which does not involve a change in the Contract Price or Contract Time.

15. "Final Acceptance" shall mean the date when the Consulting Engineer accepts in writing that the construction of the Project is complete in accordance with the Contract Documents such that the entire project can be utilized for the purposes for which it is intended and Contractor is entitled to final payment.

16. "General Requirements" shall mean those provisions of the Specifications which apply to the entire Work.

17. "Inspector" shall mean the engineering or technical inspector or inspectors duly authorized by the Consulting Engineer or the City.

18. "Notice of Award" shall mean the written notice by the City to the apparent successful Bidder stating that upon compliance with the conditions precedent enumerated therein, within the time specified, the City will sign and deliver the Agreement.

19. "Notice to Proceed" shall mean the written notice by the City to the Contractor fixing the date on which the Contract Time is to commence and on which the Contractor shall start to perform its obligations under the Contract Documents. Without the prior express written consent of the City, Contractor shall do no Work until the date set forth in the Notice to Proceed.

20. "Partial Utilization" shall mean placing a portion of the Work to be provided under the Contract Documents to the use intended by the City.

21. "Pay Estimate No. _____" or "Final Pay Estimate" shall mean the form to be used by the Contractor in requesting progress and final payments, including supporting documentation required by the Contract Documents.

22. "Plans" or "the Plans" shall mean and include all drawings which may have been prepared by the City and/or the Consulting Engineer on the City's behalf as a basis for Bids, all drawings (other than Shop Drawings, as defined in Definition No. 23, below.) submitted by the successful Bidder with its Bid or by the Contractor to the City, if and when approved by the Consulting Engineer, and all drawings submitted by the City to the Contractor during the progress of the Work, all of which show the character and scope of the Work to be performed.

23. "Shop Drawings" shall mean all drawings, diagrams, illustrations, schedules and other data which are specifically prepared by the Contractor, a Subcontractor, manufacturer, fabricator, supplier or distributor to illustrate some portion of the Work and all illustrations,

brochures, standard schedules, performance charts, instructions, diagrams and other information prepared by a manufacturer, fabricator, supplier or distributor and submitted by the Contractor to illustrate material or equipment for some portion of the Work.

24. "Specifications" shall mean those portions of the Contract Documents consisting of written technical descriptions of materials, equipment, construction methods, standards and workmanship as applied to the Work and certain administrative details applicable thereto. They may include, but not necessarily be limited to:

- (1) design specifications, e.g. measurements, tolerances, materials, inspection requirements and other information relative to the Work;
- (2) performance specifications, e.g., performance characteristics required, if any;
- (3) purchase description specifications, e.g. products or equipment required by manufacturer, trade name and/or type; provided, however, equivalent alternatives (including aesthetics, warranty and manufacturer reputation) may be substituted upon written request and written approval therefore by the City in accordance with Article GC-61;
- (4) such other information deemed appropriate by the City for inclusion in the Specifications for the proper construction of the Project.

25. "Subcontractor" shall mean an individual, firm or corporation having a direct contract with the Contractor or with another Subcontractor for the performance of a part of the Work.

26. "The Work" or "The Project" (used interchangeably) shall mean the work to be done necessary to complete the construction required of the Contractor by the Contract Documents, and includes all construction, labor, materials, tools, equipment and transportation necessary to produce such construction in accordance with the Contract Documents.

27. "Underground Facilities" shall mean all pipelines, conduits, ducts, cables, wires, manholes, vaults, tanks, tunnels or other such facilities or attachments, and any encasements containing such facilities which have been installed underground to furnish services or materials including, but not limited to, electricity, gases, steam, liquid petroleum products, telephone or other communications, cable television, sewage and drainage removal, traffic or other control systems or water.

28. "Unit Price Work" shall mean Work to be paid for on the basis of unit prices (quantity variations).

29. Whenever in these Contract Documents the words "as ordered," "as directed," "as required," "as permitted," "as allowed," or words or phrases of like import are used, it is understood that the order, direction, requirement, permission or allowance of the City and/or the Consulting Engineer is intended.

30. Whenever any statement is made in the Contract Documents containing the expression "it is understood and agreed," or an expression of like import, such expression means the mutual understanding and agreement of the parties hereto.

31. The words "approved," "reasonable," "suitable," "acceptable," "properly," "satisfactory," or words of like effect in import, unless otherwise particularly specified herein, shall mean approved, reasonable, suitable, acceptable, proper or satisfactory in the judgment of the City and/or the Consulting Engineer.

GC-3 DEFECTS IN CONTRACT DOCUMENTS

If Contractor has reasonable cause such that it should, in the exercise of ordinary care of someone in its position, know that any errors, omissions, discrepancies or inconsistencies (hereinafter "defects") appear in the Contract Documents, including, but not limited to, the Plans, Specifications and other documents or the Work, Contractor shall, notify the Consulting Engineer in writing of such defects. Contractor shall remedy any such defects whether or not disclosed to the Consulting Engineer without any increase in the cost of the Work. The Contract Documents shall be appended to all contracts between the Contractor and any Subcontractor or any more remote tier Subcontractor, and such Subcontractors and remote tier Subcontractors shall, likewise, notify the Contractor in writing of any defects therein, and it shall be the obligation of the Contractor to remedy same as if Contractor had discovered such defects itself. The Contractor will not be permitted to take advantage of any such defect.

GC-4 BID

The Contractor acknowledges and agrees that the unit prices and/or lump sum prices shown in the Bid contemplate the construction of all facilities, complete, and in conformance with the Plans and Specifications. Any item or items required in construction for which a specific unit price and/or lump sum price is not provided shall be included in the price for the closest applicable items.

GC-5 COPIES OF THE CONTRACT

Unless otherwise provided in the Contract Documents, City will furnish to Contractor a maximum of five (5) copies of the Contract Documents, free of charge, necessary for the execution of the Work.

Sufficient copies of the Bidding Documents, Bonds and Agreement between City and Contractor shall be prepared, each containing an exact copy of the Contractor's Bid as submitted, the Bonds properly executed and the Contract signed by both parties hereto. These executed counterparts shall be filed with the City, Contractor and the surety company executing the Bonds. The original Bid submitted by the Contractor will be retained by the City.

Contractor shall keep, and make available to City at the Project site, one copy of all Contract Documents for the Work at the Project site, in good order and legibly marked to reflect actual construction. Contractor shall also maintain at the site all approved samples and a print of all approved Shop Drawings. Such Documents, samples and Shop Drawings shall be turned over to the City at the completion of the Work if requested by the City.

Contract Documents are the property of the City, and none of the Contract Documents are to be used on other work by Contractor. At City's request, all Contract Documents shall be returned to the City with the exception of one record set for Contractor. All models and calculations are the property of City.

GC-6 SCOPE, NATURE AND INTENT OF PLANS AND SPECIFICATIONS

The Plans and Specifications are intended to complement, but not necessarily duplicate each other. Together they shall constitute one complete set of the Plans and Specifications, and any Work exhibited in one but not in the other shall be executed just as if it had been set forth in both in order that the Work shall be completed according to the complete design or designs as decided and determined by the Consulting Engineer.

Should anything be omitted from the Plans and Specifications which is necessary to a clear understanding of the Work, or should it appear that various instructions are in conflict, or in the event the Plans and Specifications are silent as to any detail, then it shall be the duty of the Contractor to secure written instructions from the Consulting Engineer before proceeding with the construction affected by such omissions, discrepancies or silence. In accordance with Article GC-3, Contractor's failure to bring any such matter to the attention of the Consulting Engineer shall be at the Contractor's peril, and there shall be no compensation for extra work necessitated thereby.

Dimensions and elevations shown on the Plans shall be accurately followed, even though they may differ from scaled measurements. No Work shown on the Plans, the dimensions of which are not indicated, shall be executed until the required dimensions have been obtained from the Consulting Engineer. Contractor shall be responsible for verification of all locations, dimensions and elevations in the field (including, but not limited to verification of location of Underground Facilities and utilities) and shall verify all field dimensions shown on the Contract Documents.

All Work performed under this Contract shall be done to the lines, grades, and elevations shown on the Plans. The Contractor shall keep the Consulting Engineer informed, a reasonable time in advance of the times and places at which it wishes to do Work, in order that lines and grades may be furnished and necessary measurements for record and payment may be made with the minimum of inconvenience and delay to the Consulting Engineer and the Contractor.

Any Work done without being properly located and established by base lines, offset stakes, bench marks, or other basic reference points may be ordered removed and replaced at the Contractor's cost and expense.

Contractor, together with its Subcontractors, shall carefully examine the Plans and Specifications for any interferences with the Work and clearances that may be required. Contractor shall be responsible for the proper fitting of materials and equipment without substantial alterations. Contractor shall be responsible for eliminating interferences without additional cost to City. If departures from the Plans and Specifications, or other Contract Documents, are deemed necessary by Contractor, details of such departures and reasons therefore shall be submitted to Consulting Engineer, with drawings (if Consulting Engineer determines that drawings are necessary), for approval as soon as practical. No such departure shall be made except at the peril of the Contractor without the prior written approval of the Consulting Engineer.

GC-7 BEGINNING, PROGRESS AND TIME OF COMPLETION OF WORK

After being awarded the Contract, the Contractor shall immediately prepare and submit for approval by the City Engineer a construction schedule giving the dates on which it expects to start and to complete separate portions of the Work, which schedule shall be strictly adhered to unless agreed to in writing by all parties or modified by any extension or extensions of time as hereinafter provided. The schedule shall be submitted before the Notice to Proceed is issued.

No Work on this Contract shall begin until said schedule is approved. The City reserves the right to adjust the Contractor's schedule to coordinate with any other projects in the same area.

The Contractor shall, within ten (10) days after being instructed to do so in the written "Notice to Proceed" from the City, commence the Work to be done under this Contract; and the rate of progress shall be such that the Work shall have been completed in accordance with the terms of the Contract on or before the termination of the construction period contractually specified, subject to any extension or extensions of such time made as hereinafter provided.

The Contractor shall submit monthly progress reports and schedules. The progress report shall summarize Work completed, identify any weather and/or utility delays encountered, and indicate Work anticipated for the upcoming month. The schedule will be detailed indicating how the remaining Work will be completed within the stated deadlines (the remaining Work shall include identifying/incorporating utility relocation work with the project-related construction work). The progress report and schedule will be required before payment of monthly pay estimates.

If requested, a weekly construction schedule shall be submitted to the City and approved by the City Engineer. Modifications and/or revisions to the schedule shall have twenty-four (24) hour notice with approval by the City Engineer.

GC-8 SHOP DRAWINGS

Contractor shall review, approve, and submit, with such promptness as to cause no delay in its own Work or in that of any Subcontractor or other Contractor, three (3) copies of all shop, fabrication, assembly, foundation and other drawings and schedules required by the Specifications, including, but not limited to: (1) drawings of equipment and devices offered by the Contractor for approval of the Consulting Engineer in sufficient detail to adequately show the construction and operation thereof; (2) drawings showing essential details of any change in design of construction proposed, for consideration by the Consulting Engineer, by the Contractor in lieu of the design or arrangement required by the Contract Documents, or any item of extra work there under; (3) all required wiring and piping layouts; and (4) structural and reinforcing fabrication drawings. All submittals, regardless of origin, shall be stamped with the approval of the Contractor and identified with the name and number of this Contract, Contractor's name and references to applicable specification paragraphs and Contract drawings. Each submittal shall indicate the intended use of the item in the Work. Contractor's stamp of approval is representation to the Consulting Engineer, that the Contractor accepts full responsibility for determining and verifying all quantities, dimensions, field construction criteria, materials, and similar data, and that he has reviewed or coordinated each submittal with the requirements of the Work and the Contract Documents. All deviations from the Contract Documents shall be identified on each submittal and shall be tabulated in the Contractor's letter of transmittal. Such submittals shall, as pertinent to the deviation, indicate essential details of all changes proposed by Contractor (including modifications to other facilities that may be a result of each deviation).

The Consulting Engineer shall review the Shop Drawings for conformance with the design concept of the Work and information as given in the Contract Documents. The Contractor is not relieved of responsibility for any deviation from the requirements of the Contract Documents by the Consulting Engineer's approval of the Shop Drawings, product data, or samples. The Contractor is not relieved from responsibility for errors or omissions in Shop Drawings by the Engineer's approval thereof. The Consulting Engineer shall respond to, accept or reject such submissions within a reasonable time after receipt thereof. Contractor shall make such revisions as deemed necessary. On Final Acceptance, the Consulting Engineer shall be furnished with a total of five (5) copies of each drawing as finally approved, such number to

include any copies of preliminary or revised drawings which are approved as submitted. No Work shall be performed in connection with the fabrication or manufacture of material or equipment shown by any drawing thereof, nor shall any accessory, appurtenance or device not fabricated or manufactured by the Contractor or its Subcontractors be purchased, until the drawing or drawings therefore have been approved as stipulated, except at the Contractor's own risk and responsibility.

GC-9 CONTRACTOR'S RESPONSIBILITIES AS TO AMBIGUITIES

If there is any ambiguity in Consulting Engineer's drawings or instructions, Contractor shall ask the Consulting Engineer for clarification. Upon written request of Contractor, the Consulting Engineer shall furnish, with reasonable promptness, additional instructions by means of drawings, Specifications or other information necessary for the proper execution of the Work. The Work shall be executed in conformity therewith, and, in accordance with Article GC-3, Contractor shall do no Work without proper instructions except at its peril. Nothing herein to the contrary shall affect Contractor's responsibilities with regard to defects as set forth in Article GC-3.

GC-10 CONCEALED CONDITIONS

The Contractor understands that the City does not warrant that the various and sundry materials and information, including, for example, soil tests, bore reports, utility locations and other such data and as-builts in the case of renovation of or addition to existing facilities, reflect actual conditions. The Contractor warrants that it has examined the site and conducted such tests and examinations as it deems necessary. That being the case, should concealed conditions encountered in the performance of the Work below the ground or should concealed or unknown conditions in an existing structure be at variance with the conditions indicated by the Contract Documents, or should unknown physical conditions below the surface of the ground or should concealed or unknown conditions in an existing structure of an unusual nature, differing materially from those ordinarily encountered and generally recognized as inherent in work of the character provided for in this Contract, be encountered, there shall be no adjustment in the Contract Price for any extra work necessitated thereby, although, if necessary, the Contract Time may be adjusted.

GC-11 CONTRACTOR TO FURNISH STAKES AND HELP

The Contractor, unless otherwise instructed, shall stake the Work and shall furnish, without charge, competent people from its force and such tools, stakes, and other materials as required in properly staking out the Work, in making measurements and surveys and in establishing temporary or permanent reference marks in connection with said Work. The stakes furnished for the staking of the Work shall be of such type, size and quality as to be acceptable to the Consulting Engineer.

GC-12 PRESERVATION OF MONUMENTS AND STAKES

The Contractor shall carefully preserve all monuments, property corners, bench marks, reference points and stakes, and in case of destruction of the same, will be responsible for proper replacement and for any mistakes or loss of time that may be caused by their unnecessary loss or disturbance. In the event that the loss of stakes, etc., causes a delay in the Work, the Contractor shall have no claim for damages or extensions of time. In the case of any permanent monuments, property corners or bench marks which must of necessity be removed or disturbed in the construction of the Work, the Contractor shall carefully protect and preserve the same until they can be properly referenced for relocation. The Contractor shall furnish at its

own expense such materials, surveyors and assistance as are necessary for the proper replacement of monuments, property corners or bench marks that have been moved or destroyed.

GC-13 PERMITS AND NOTICES

(a) All permits and licenses shall be secured and paid for by Contractor, unless otherwise specified.

(b) Contractor shall give all notices required by and all Work shall be done in accordance with all applicable federal and state laws, City and County laws and ordinances, building codes and rules and regulations bearing on the conduct of the Work.

(c) Contractor shall notify all affected utilities of the Work and coordinate with the utilities to avoid interruption of utility service and damage to utility lines and property. This notice requirement shall also apply as to the owner/operator of any affected Underground Facility. Any project delay, damages or increase in construction costs due to utility relocation delays shall be at the Contractor's risk.

GC-14 GENERAL ADMINISTRATION OF THE CONTRACT

(a) Unless otherwise stipulated, Contractor shall provide and initially pay for all Work (including labor, transportation, tools, equipment, machinery, plant and appliances) necessary in producing the results called for by the Contract Documents.

(b) Unless otherwise specified, all supplies, materials, equipment and other facilities are guaranteed to be new and all Work shall be of good quality and workmanship and free from defects or fault. Contractor shall, if required, furnish satisfactory evidence as to the kind and quality of the Work.

(c) The Contractor shall be solely responsible for and have complete control and charge of construction means, methods, techniques, sequences and procedures, and for safety precautions and programs in connection with the Work. The City shall not be responsible for nor have control or charge over the acts or omissions of the Contractor, Subcontractors, or any of their agents or employees, or any other persons performing any of the Work.

(d) The Contractor shall, in addition to the schedule required by Article GC-7, give to the Consulting Engineer full information in advance as to its plans for carrying on any part of the Work. If at any time before the beginning or during the progress of the Work, any part of the Contractor's plant or equipment or any of its methods of executing the Work, appear to the Consulting Engineer to be unsafe, inefficient or inadequate to ensure the required quality or rate of progress of the Work, the Consulting Engineer may order the Contractor to increase or improve its facilities or methods, and the Contractor shall promptly comply with such orders; but neither compliance with such orders nor failure of the Consulting Engineer to issue such orders shall relieve the Contractor from its obligation to secure the degree of safety, the quality of Work and the rate of progress required by the Contract.

(e) The approval by the Consulting Engineer of any plan, schedule or method of work proposed by the Contractor shall not relieve the Contractor of any responsibility therefore, and such approval shall not be considered as an assumption by the City, or any officer, agent or employee thereof, of any risk or liability, and the Contractor shall have no claim under this Contract on account of the failure or inefficiency of any plan or method so approved. Such approval shall be considered and shall mean that the Consulting Engineer has no objection to

the Contractor's use or adoption, at the Contractor's own risk and responsibility, of the plan or method so proposed by the Contractor.

(f) Any plan or method of Work suggested by the Consulting Engineer or the City, to the Contractor, but not specified or required, if adopted or followed by the Contractor in whole or in part, shall be used at the risk and responsibility of the Contractor, and the Consulting Engineer and the City will assume no responsibility therefor.

GC-15 CONTRACTOR'S EMPLOYEES

(a) Contractor shall at all times enforce strict discipline and good order among its employees and shall not employ on the Work any unfit person or anyone not skilled in the Work assigned to him.

(b) Contractor shall be responsible for compliance with all state and federal laws, if applicable, pertaining to wages, hours and benefits for workers employed to carry out the Work.

GC-16 SAMPLES

Contractor shall furnish for approval samples if directed by the Consulting Engineer or the Contract Documents. The Work shall be in accordance with approved samples.

GC-17 PROTECTION AND MAINTENANCE OF PUBLIC AND PRIVATE PROPERTY; LIABILITY

(a) Contractor shall be solely liable for all damages to the City or the property of the City, to other contractors or other employees of the City, to neighboring premises, or to any private or personal property, due to improper, illegal or negligent conduct of the Contractor, its Subcontractors, employees or agents in and about said Work, or in the execution of the Work. The Contractor shall be liable to the City for any damages, whether property damage or personal injury, occasioned by Contractor's use of any scaffolding, shoring, apparatus, ways, works, machinery, plant or any other process or thing that is required for the Work.

(b) Without in any manner limiting Contractor's responsibilities as provided elsewhere in the Contract Documents, the Contractor shall maintain at all times, as required by the conditions and progress of the Work, all necessary safeguards, and assume full responsibility, for the protection of all public and private property, life, the Work, supplies, materials and equipment on the Project site not yet incorporated in the Work, structures, sewers and utilities both above the ground and Underground Facilities, along, beneath, above, across or near the site or sites of the Work being performed under this Contract, or which are in any manner affected by the prosecution of the Work or the transportation of people or materials in connection therewith.

(c) Protection may include, shoring, bracing, supporting and maintaining all underground pipes, conduits, drains and other underground construction uncovered or otherwise affected by the construction Work performed by Contractor. Barriers shall be kept placed at all times to protect bracing and shoring of the trenches shall be in full accordance with Occupational Safety and Health Standards – Excavations; Final Rule 29 CFR Part 1926. All open trenches and other excavations shall be provided with suitable barriers, signs and lights, at Contractor's expense, such that adequate protection is provided to the public against accident by reason of such open construction. Obstructions such as material piles and equipment shall be provided with similar warning lights and signs. All pavement, surfaces, driveways, curbs, walks, buildings, utility poles, guy wires, and other surface structures affected by construction

operations in connection with the performance of the Contract, shall be maintained, and if removed or otherwise damaged, shall be restored to the original condition thereof, as determined and approved by the Engineer. All replacement of such underground construction and surface structures or parts thereof shall be made with new materials conforming to the requirements of these Specifications, or if not specified, as approved by the Engineer, at the Contractor's own expense, unless otherwise provided by the Contract.

(d) Barriers shall be kept placed at all times to protect other than those engaged on or about the Work from accident and the Contractor shall be held responsible for all accidents to persons or property resulting from the acts of Contractor or its employees. Contractor shall give reasonable notice to any affected owner or owners when any property is liable to injury or damage through the performance of the Work and shall make all necessary arrangements with such owner or owners relative to the removal and replacement or protection of such property and/or utilities.

(e) Contractor shall comply with any and all instructions from the Consulting Engineer regarding prevention of accidents, fires or for the elimination of any unsafe practice and shall observe all the applicable recommendations of the National Fire Protection Association Standard No. 241 (or other, later revision) "Standards For Safeguarding Building Construction and Demolition Operations".

(f) Contractor shall post danger signs warning against the hazards created by such features of construction as protruding nails, hood hoists, well holes, elevator hatchways, scaffolding, window openings, stairways, falling materials, open trenches, other excavations, obstructions and similar conditions. It shall designate a responsible member of its organization on the Project whose duty shall be the prevention of accidents. The name and position of the person so designated shall be reported to the Consulting Engineer by Contractor.

(g) In an emergency affecting the safety of life, the Work, City's property or of adjoining property, Contractor, without special instruction or authorization from the Consulting Engineer, is hereby permitted to act, at its discretion, to prevent such threatened injury or loss. Any compensation claimed by Contractor on account of emergency work shall be determined by mutual agreement of City and Contractor.

(h) Contractor shall develop and maintain an up-to-date emergency action plan, taking into account fires, hazardous materials, explosions, adverse weather, floods, etc., which shall be in compliance with all federal, state and local laws and ordinances. The procedures should outline specific action to be taken to protect life and to secure and protect the building materials, constructed work, buildings, equipment and the position of cranes. Contractor shall be fully responsible for the contents of and procedures outlined in said plan, including deficiencies therein, whether or not City shall have reviewed said plan.

(i) Contractor shall be responsible for any damage caused by settlement of backfill placed beneath pavement, street, road, and driveway surfacing, and drainage and other structures beneath yards, parking and parks, which may occur at any time prior to and during a period of two (2) years from and after the date of Final Acceptance of Work covered by the Contract; during such period, the Contractor shall at his own expense, refill all excavations where backfill settlement has occurred, and shall repair or cause to be repaired all damage to structures, pavements, surfacing and sod caused by such settlement, to the satisfaction of the City. Should the Contractor fail to repair settlements, which may occur as described above within thirty (30) days after being given notice thereof, the City shall have the right to repair such settlement and charge the cost of such repairs to the Contractor.

(j) Contractor shall be held responsible for all damage to roads, highways, shoulders, ditches, embankments, bridges, culverts, and other property, caused by the Contractor or any of the Contractor's Subcontractors in hauling or otherwise transporting materials to or from the several sites of Work, regardless of the location of such damage. Contractor shall make arrangements relative to the payment for, or repair or replacement of, such damage or damaged surfaces of structures; said arrangements shall be satisfactory and acceptable to the owner or owners of such damaged surfaces or structures, or to their legally responsible officers, agents or other representatives, and said payment shall be at the Contractor's own cost and expense, unless otherwise provided by the Contract.

(k) All streets, roads, highways and other public thoroughfares which are closed to traffic, under the authority of a proper permit, shall be protected, at Contractor's expense, by means of effective barricades on which shall be placed proper warning signs; such barricades being located at the nearest intersecting public highway or street on each side of the blocked section of such public thoroughfare.

(l) All barricades and obstructions shall be illuminated by means of amber lights at night and all lights used for this purpose shall be at Contractor's expense and shall be kept burning from sunset to sunrise. Materials stored upon or alongside public streets and highways shall be so placed, and the Work at all times shall be so conducted, as to cause the minimum obstruction and inconvenience to the traveling public.

(m) All barricades, signs, lights and other protective devices in public rights-of-way shall be installed and maintained in conformity with applicable statutory requirements and as required by the Manual on Uniform Control Devices, as amended, or any other applicable statutes or ordinances.

GC-18 WORK IN OR ACROSS STREET OR HIGHWAY RIGHT-OF-WAY

All Work performed and all preparations of the Contractor or its employees, and Subcontractors, if any, within the limits of street or highway rights-of-way shall be in conformity with the requirements, and be under the control, through the City, of the street or highway authority owning or having jurisdiction and control over such rights-of-way in each case. Any costs incurred to comply with such requirements are the responsibility of Contractor.

GC-19 MAINTENANCE OF TRAFFIC

Local traffic on all streets shall be carried through construction whenever possible. Detours of traffic will be permitted when necessary and with the prior permission of the City. Streets may be closed for short periods of time under authority of proper permit issued by the City or authority having jurisdiction. However, the Contractor shall conduct its Work so as to interfere as little as possible with public travel, whether vehicular or pedestrian, on such streets. Proper notification to County and City police units and to Fire Districts shall be given by the Contractor before closing any public thoroughfare.

Where construction operations require the closing of private driveways, the Contractor shall give adequate notice to the owner or owners thereof and where necessary shall provide temporary access to private property.

GC-20 NOISE CONTROL

Contractor shall take reasonable measures to avoid unnecessary noise. Such measures shall be appropriate for the normal ambient sound levels in the area during working hours. All

construction machinery and vehicles shall be equipped with practical sound muffling devices, and operated in a manner to cause the least noise consistent with efficient performance of the Work.

GC-21 DUST CONTROL

Adequate precaution shall be taken to insure that excessive dust does not become airborne during construction. The Contractor shall comply with any local, state, or federal regulations which apply to this matter in the geographical area of the Work. No separate payment will be made for performing dust control or for applying water for this purpose.

GC-22 INSPECTION OF WORK

(a) Consulting Engineer shall at all times have access to the Work for the observation and inspection thereof wherever it is in preparation or progress, and Contractor shall provide proper facilities for such inspection. The Contractor shall furnish all reasonable aid and assistance required for any such inspection.

(b) All Work must be inspected, tested or approved and the Contractor shall give the Consulting Engineer timely notice of its readiness for such inspection, testing or approval and the date fixed for such inspection, testing or approval, if the inspection, testing or approval is by an authority other than Consulting Engineer. If any Work should be covered up which is required by the above to be inspected, tested or approved and which, by virtue of being so covered up, is not susceptible to being properly inspected, tested or approved, Contractor shall, if requested by Consulting Engineer, uncover such Work and at Contractor's expense bear the cost of uncovering such Work and redoing same after inspection, testing or approval and redoing such other Work damaged as a result of having to uncover and redo same.

(c) Consulting Engineer reserves the right to inspect any and all Work before it is covered up; and, accordingly, Contractor must notify Consulting Engineer before covering any Work. Consulting Engineer shall be given a reasonable time to make its inspection. Contractor shall not cover any Work prior to Consulting Engineer having a reasonable time to inspect. If Work to be covered does not conform to the Contract Documents, Consulting Engineer can withhold its consent to covering up Work until such Work is made to conform at Contractor's expense.

(d) If any labor, supplies, materials or equipment are found not to be in accordance with the Contract Documents, Contractor shall at its own expense bear the cost of uncovering such labor, supplies, materials or equipment, the cost of removing same, as well as the cost of undoing and redoing the Work and other Work damaged by such nonconforming labor, supplies, materials or equipment.

(e) The Contractor shall comply with the directions and instructions of the Consulting Engineer.

(f) The City, the Consulting Engineer and all designated Inspectors shall be free at all times to perform their duties, including the observation and inspection of the Work, and intimidation or attempted intimidation of any one of them by the Contractor or by any of its employees shall be sufficient reason, if the City so desires, to terminate the Contract.

(g) Any inspection, by whosoever conducted, shall not relieve the Contractor from any obligation to perform the Work strictly in accordance with the Plans and Specifications, and

any of the Work not so constructed shall be removed and made good by the Contractor at its own expense.

GC-23 SUPERINTENDENCE AND SUPERVISION

The Contractor shall be responsible for coordination between all phases of the Work and provide all necessary supervision to the Work using its best skill, care, judgment and attention and shall keep on the Work, during its progress, a competent superintendent and any necessary assistants, all satisfactory to Consulting Engineer. The Contractor shall coordinate the activities and scheduling of all operations in accordance with the approved schedule. All unsupervised Work shall be unacceptable and subject to removal and replacement at the Contractors expense. The superintendent shall not be changed except with the consent of the Consulting Engineer unless the superintendent proves to be unsatisfactory to the Contractor and/or ceases to be in its employ; provided however, that the Consulting Engineer retains the right to require that the Contractor replace the superintendent at any time, such right not to be arbitrarily exercised.

The superintendent shall be fully authorized to act for the Contractor and receive whatever orders as may be given for the proper prosecution of the Work or notices in connection therewith. Use of Subcontractors on portions of the Work shall not relieve the Contractor of its obligation to have a competent superintendent directly employed by the Contractor on the Work at all times.

GC-24 CONTRACTOR'S OFFICE AT SITE OF WORK

During the performance of this Contract, the Contractor shall maintain a suitable office at or near the site of the Work which shall be the headquarters of the superintendent authorized to receive drawings, instructions, or other communications or articles from the Consulting Engineer, and any such communication given to the said superintendent or delivered at the Contractor's office at the site of the Work in his/her absence shall be deemed to have been given to the Contractor.

GC-25 CHANGES IN THE WORK

(a) Change Orders. City, without invalidating the Contract, may by Change Order direct changes in the Work which may result in an addition to or deduction from the Contract Price and/or changes in the Contract Time. All Change Orders shall be executed under the provisions of the original Contract Documents. If the Change Order consists of a modification to the Contract Price, the value of such change shall be determined as per paragraph (e) below.

Except for Work done as a result of an emergency endangering life or property, no Work resulting in an additional pay item shall be performed unless pursuant to the provisions of a Change Order.

(b) Quantity Variations. Where changes in the Work involve a change in the quantity of any Bid item, the Contract Price shall be revised by extension of the quantities and unit price of all Bid items so changed subject to written approval of the Consulting Engineer.

(c) Field Orders. Consulting Engineer may order minor changes in the Work through Field Orders, which in no specific, concrete or substantial way increase or decrease the Work;

and such minor changes in the Work shall not involve an addition or deduction from the Contract Price.

(d) From time to time the Consulting Engineer may also issue written orders to Contractor for needed clarifications, modifications or corrections. Should a difference of opinion arise as to whether the order constitutes extra work for which additional compensation is due, and the City insists on its performance, the Contractor shall proceed with the Work after making a written request for a Change Order, and it shall keep an accurate account of the actual field cost thereof as provided for in (e)(3) below. The Contractor will thereby preserve the right to submit a claim therefor.

(e) The value of any change in the Work which results in an addition/deletion to the Contract Price shall be determined in one or more of the following ways, at the option of City:

- (1) By agreed lump sum.
- (2) By unit prices named in the Contract or subsequently agreed upon.
- (3) By actual field cost (time and material) plus fifteen percent (15%) and shall include a "Not to Exceed" figure.

In order to arrive at the value for any change, Contractor shall credit City with its projected cost(s), including overhead and fee for any Work which was previously included but which has been excluded by any such change.

(f) No change in the Work shall entail additional time unless the Consulting Engineer determines that additional time is required and specifically so provides in the Change Order. No change in the Work shall entitle the Contractor to delay damages.

(g) Where extra work is performed under (e)(3) above, the term "actual field cost" of such extra work is hereby defined to be and shall include:

- (1) The cost of all workers, such as foremen, timekeepers, mechanics, and laborers, for the time actually employed in the performance of the said extra work;
- (2) All materials and supplies;
- (3) Trucks and rentals on machinery and equipment for the time actually employed or used in the performance of said extra work;
- (4) Any transportation charges necessarily incurred in connection with said equipment authorized by the Consulting Engineer for use on said Work and similar operating expenses;
- (5) All incidental expenses incurred as a direct result of such extra work, including payroll taxes and a ratable proportion of premiums on construction Bonds and, where the premiums therefore are based on payroll costs, public liability and property damage, worker's compensation, and other insurance required by the Contract; provided, however, Contractor must enumerate and justify to City's satisfaction any such claimed incidental expenses; and provided, further, that without in any way limiting City's right to challenge any individual costs claimed by Contractor, incidental costs shall not include:

- (A) Payroll costs and other compensation of Contractor's officers, executives, principals (of partnership and sole proprietorships), general managers, engineers, architects, estimators, lawyers, auditors, accountants, purchasing and contracting agents, expeditors, timekeepers, clerks and other personnel employed by Contractor whether at the site or in Contractor's principal or a branch office for general administration of the Work unless specifically agreed to by City - all of which are to be considered administrative costs covered by the Contractor's overhead and profit.
- (B) Expenses of Contractor's principal and branch offices other than Contractor's office at the site.
- (C) Any part of Contractor's capital expenses, including interest on Contractor's capital employed for the Work and charges against Contractor for delinquent payments.
- (D) Costs due to the negligence of Contractor, any Subcontractor, or anyone directly or indirectly employed by any of them or for whose acts any of them may be liable, including but not limited to, the correction of Defective Work, disposal of materials or equipment wrongly supplied and making good any damage to property.
- (E) Other overhead of general expense costs of any kind and the costs of any item not specifically and expressly agreed to by City.

The Consulting Engineer may direct the form in which accounts of the actual field cost shall be kept and may also specify in writing, before the Work commences, the method of doing the Work and the type and kind of machinery and equipment, if required, which shall be used in the performance of extra work under (e)(3) above. In the event that machinery and heavy construction equipment shall be required for such extra work, the authorization and basis of payment for the use thereof shall be stipulated in the written extra work order.

The fifteen percent (15%) of the actual field cost to be paid to the Contractor shall cover, and be full compensation for, the Contractor's profit, overhead, general superintendence, field office expense and all other elements of cost not embraced within the "actual field cost" as herein defined.

(h) In the event that unit prices are provided for in the Contract Documents as to all or a part of the Work, if the quantities originally contemplated are so changed in a proposed Change Order that application of the agreed unit prices to the quantities of Work proposed is substantially inequitable to either the City or the Contractor, the unit prices shall be reevaluated and adjusted in accordance with the following:

- (1) If the total cost of a particular item of Unit Price Work amounts to twenty percent (20%) or more of the Contract price and the variation in the quantity of that particular item of Unit Price Work performed by Contractor differs by more than thirty-three percent (33%) from the estimated quantity of such item indicated in the Contract; and

- (2) If there is no corresponding adjustment with respect to any other item of Work; and
- (3) If Contractor has incurred additional expense as a result thereof; or
- (4) If City believes that the quantity variation entitles it to an adjustment in the unit price and, the parties are unable to agree as to effect of any such variations in the quantity of Unit Price Work performed; then either City or Contractor may request the Consulting Engineer to make an adjustment in the Contract price.

(i) No claim for extra work of any kind will be allowed except as provided herein. If extra work orders are given in accordance with the provisions of this Contract, such Work shall be considered a part hereof and subject to each and all of the terms and requirements of this Contract.

(j) Contractor shall be responsible for notifying its surety(ies) of any modifications to the Contract price or time, and said surety(ies) shall not seek discharge as a result of any failure on Contractor's part to notify surety(ies).

GC-26 DEDUCTIONS FOR UNCORRECTED WORK

If City deems it inexpedient to have corrected any Work which is not in accordance with the Contract Documents, an equitable deduction from the Contract Price shall be made therefor.

GC-27 DELAYS AND EXTENSION OF TIME

(a) If Contractor shall be delayed at any time in the progress of the Work by an act or omission of City or by any separate contractor employed by City and over which Contractor has no control and which is not a result of the Contractor's acts or the acts of any of its employees, Subcontractor or suppliers, negligent or otherwise, then the time of completion shall be extended for such reasonable time as the Consulting Engineer shall decide, and no adjustment shall be made in the Contract Price.

(b) No such extension shall be made for delay unless Contractor provides written notice to Consulting Engineer of such delay, the reasons therefore and the expected length of delay within seven (7) days of the commencement of such delay. In the case of a continuing cause of delay, only one claim is necessary.

(c) In executing the Contract, the Contractor expressly covenants and agrees that, in undertaking to complete the Work within the time therein fixed, it has taken into consideration and made allowances for all hindrances and delays incident to such Work, whether growing out of delays in securing materials, workers, weather conditions or otherwise. No charge shall be made by the Contractor for hindrances or delays from any cause during the progress of the Work, or any portion thereof, included in this Contract, except as provided in subparagraph (a), (b), or (d) of this Article.

(d) The Contractor shall delay or suspend the progress of the Work or any part thereof, whenever it shall be so required by written order of the Consulting Engineer, and for such periods of time as the Consulting Engineer shall require; provided, that in the event of such delay or delays or of such suspension or suspensions of the progress of the Work, or any part thereof, the time for completion of Work so suspended or of Work so delayed by such suspension or suspensions shall be extended for a period equivalent to the time lost by reason

of such suspension or suspensions; but such order of the Consulting Engineer shall not otherwise modify or invalidate in any way, any of the provisions of this Contract. In the event that the Work shall be stopped by order of the Consulting Engineer, through no fault of the Contractor, its employees, Subcontractors or suppliers, any incidental expenses (see Article GC-25 (g)(5)) which, in the opinion and judgment of the Consulting Engineer, are caused thereby shall be paid by the City to the Contractor; provided, however, that such suspension or suspensions shall not be the basis for any claim by Contractor for additional compensation or damages for delay.

(e) The City reserves the right and may delay Work on certain portions of Work until such time as weather and/or utility relocations will allow proper progress on major items of Work. The City may direct the Contractor to clear the right-of-way before utility relocations, if, in the opinion of the Engineer, such clearing would expedite utility relocation. Also, the City may direct the Contractor to work on certain items of Work after partial utility relocations have been made. There shall be no charge made by the City or the Contractor for delays arising from the issuance of such delayed Work direction other than provided for in paragraphs (a) through (d) in this Article.

GC-28 WORK STOPPAGES

Contractor warrants to the City that there shall be no work stoppages or interruptions arising out of labor disputes, including, but not limited to, those due to the presence of both union and non-union workforces at the job site. Contractor further agrees that in the event of any strike, picket, sympathy strike, work stoppage or other form of labor dispute or picket in connection with the Work of the Contractor, other contractors, Subcontractors, the City, or any other person, the Contractor will, contingent upon the City providing a picket-free entrance, continue to perform the Work required herein without interruption or delay. Anything in this Contract to the contrary notwithstanding, in the event the Contractor fails to continue performance of the Work included herein without interruption or delay, because of such picket or other form of labor dispute, the City may terminate the services of said Contractor after giving forty-eight (48) hours written notice to Contractor and its sureties of its intent to do so, or the City may invoke any of the rights set forth elsewhere in the Contract Documents.

GC-29 PATENT LIABILITY CLAUSE

Contractor agrees to defend any claim, action or suit that may be brought against City, its Governing Body, officers, agents or employees for infringement of any patents arising out of the performance of this Contract or out of the use or disposal by or for the account of City of supplies furnished or construction Work performed hereunder, and also to indemnify and hold harmless City, its Governing Body, officers, agents, and employees against all judgments, decrees, damages, costs and expenses recovered against it or them or sustained by it or them on account of any such actual or alleged infringement.

It is understood that all royalties and fees for and in connection with patents, or patent infringement, claims for materials, articles, apparatus, devices or equipment used in or furnished for the Work shall be included in the Contract Price. Final payment to the Contractor by the City shall not be made while any suit or claim involving infringement or alleged infringement of any patent remains unsettled.

GC-30 INDEPENDENT CONTRACTOR

The right of general supervision of the City and/or the Consulting Engineer shall not make the Contractor an agent of the City, and the liability of the Contractor for all damages to

persons, firms and corporations arising from the Contractor's execution of the Work shall not be lessened because of such general supervision, but as to all such persons, firms and corporations, and the damages, if any, to them or their property, the Contractor herein is an independent contractor in respect to the Work.

GC-31 SEPARATE CONTRACTS

(a) City reserves the right to perform by itself or let other contracts in connection with Work. Contractor shall afford reasonable opportunity for the introduction and storage of materials and the execution of Work by City or others and shall properly connect and coordinate its Work with the Work of City or others.

(b) If any part of Contractor's Work depends upon the Work of the City or others, Contractor shall inspect and promptly report to City any defects in any such Work that render it unsuitable for proper execution or results. Its failure to so inspect and report shall constitute an acceptance by it of such other Work as fit and proper for the reception of its Work.

GC-32 RELATIONS WITH OTHER CONTRACTORS

The Contractor shall cooperate with all other contractors or workers who may be performing Work on behalf of the City or any other entity on any Work in the vicinity of the Work to be done under this Contract, and it shall so conduct its operations as to interfere to the least possible extent with the Work of such Contractors or workers. Contractor shall be responsible for any injury or damages that may be sustained by other contractors, workers or their Work because of any fault or negligence on Contractor's part, and shall at its own expense repair or pay for such injury or damage. Any difference or conflict which may arise between the Contractor and other contractors, or between the Contractor and the workers of the City or any other entity, in regard to their Work, shall be adjusted and determined by the Consulting Engineer. If the Work of the Contractor is delayed or damaged because of any acts or omissions of any other contractor or contractors, the Contractor shall have no claim against the City on that account; provided, however, the City may, in its discretion, grant an extension of time.

When two or more contracts are being executed at one time in such manner that Work on one Contract may interfere with that on another, the Consulting Engineer shall decide which contractor shall cease Work and which shall continue, whether the Work on both contracts shall progress at the same time, and in what manner the Work is to proceed.

When the territory of one contract is the necessary or convenient means of access for the transportation or movement of men/women, materials or appliances required for the execution of another contract, such privileges of access or any other responsible privilege may be granted by Consulting Engineer to the Contractor so desiring to the extent which may be reasonably necessary.

In the event that Contractor is performing Work at a site or on a project involving City and one or more other private or governmental entities, which have their own contractors on site as well, Contractor shall advise Consulting Engineer when it anticipates that there may be interference with the Contractor's Work or with the Work of any other contractor. Consulting Engineer shall, to the best of its ability, with input from Contractor as to coordination of the Work, seek to schedule Work of the various contractors so as to avoid as much inconvenience and delay as possible; provided, however, that in the event Contractor experiences a delay or damage to the Contractor's Work as a result of the presence of other such contractors, Contractor shall not be entitled to additional compensation or damages for delay or damage to

the Contractor's Work; rather, Contractor's only recourse shall be an extension of time to be determined by the Consulting Engineer.

GC-33 INDEMNITY

(a) Definitions

For purposes of indemnification requirements as set forth throughout the Contract, the following terms shall have the meanings set forth below:

- (1) "The Contractor" means and includes Contractor, all of its affiliates and subsidiaries, its Subcontractors and materialmen and their respective servants, agents and employees; and
- (2) "Loss" means any and all loss, damage, liability or expense, of any nature whatsoever, whether incurred as a judgment, settlement, penalty, fine or otherwise (including attorney's fees and the cost of defense), in connection with any action, proceeding, demand or claim, whether real or spurious, for injury, including death, to any person or persons or damages to or loss of, or loss of the use of, property of any person, firm or corporation, including the parties hereto, which arise out of or are connected with, or are claimed to arise out of or be connected with, the performance of this Contract whether arising before or after the completion of the Work required hereunder.

(b) The Indemnity

For purposes of this Contract, and without in any way limiting indemnification obligations that may be set forth elsewhere in the Contract, Contractor hereby agrees to indemnify, defend and hold harmless the City from any and all Loss where Loss is caused or incurred or alleged to be caused or incurred in whole or in part as a result of the negligence or other actionable fault of the Contractor, its employees, agents, Subcontractors and suppliers.

It is agreed as a specific element of consideration of this Contract that this indemnity shall apply notwithstanding the joint, concurring or contributory or comparative fault or negligence of the City or any third party and, further, notwithstanding any theory of law including, but not limited to, a characterization of the City's or any third party's joint, concurring or contributory or comparative fault or negligence as either passive or active in nature.

(c) General Limitation

Nothing in this Article shall be deemed to impose liability on the Contractor to indemnify the City for Loss when the City's negligence or other actionable fault is the sole cause of Loss.

(d) Waiver of Statutory Defenses

With respect to the City's rights as set forth herein, the Contractor expressly waives all statutory defenses, including, but not limited to, those under workers compensation, contribution, comparative fault or similar statutes to the extent said defenses are inconsistent with or would defeat the purposes of this Article.

GC-34 PROTECTION OF PROPERTY/LIABILITY

Without in any manner limiting Contractor's responsibilities as provided elsewhere in the Contract Documents, the Contractor shall assume full responsibility for the protection of all public and private property, structures, sewers and utilities, both above the ground and Underground Facilities, along, beneath, above, across or near the site or sites of the Work being performed under this Contract, or which are in any manner affected by the prosecution of the Work or the transportation of men/women or materials in connection therewith. Barriers shall be kept placed at all times to protect persons other than those engaged on or about the Work from accident, and the Contractor will be held responsible for all accidents to persons or property resulting from the acts of Contractor or its employees.

The Contractor shall give reasonable notice to the affected owner or owners when any such property is liable to injury or damage through the performance of the Work and shall make all necessary arrangements with such owner or owners relative to the removal and replacement or protection of such property and/or utilities.

The Contractor shall satisfactorily shore, support and protect any and all structures and all pipes, sewers, drains, conduits and other facilities and shall be responsible for any damage resulting thereto. The Contractor shall not be entitled to any additional time on account of any postponement, interference or delay caused by any such structures and facilities being on the line of the Work, whether they are shown on the Plans or not.

GC-35 PROVISION FOR EMERGENCIES

Whenever, in the opinion of the Consulting Engineer, the Contractor has not taken sufficient precaution for the safety of the public or the protection of the Work to be constructed under this Contract, or of adjacent structures or property which may be injured by process of construction, and whenever, in the opinion of the Consulting Engineer, an emergency shall arise and immediate action shall be considered necessary in order to protect property interests and to avoid personal injury and/or death, then the Consulting Engineer, with or without notice to the Contractor, shall, upon notification to the City, provide suitable protection to the said interests by causing such Work to be done and materials to be furnished at places as the Consulting Engineer may consider necessary and adequate. The cost and expense of such Work and material so furnished shall be borne by the Contractor and, if the same shall not be paid on presentation of the bills therefore, such costs shall be deducted from any amounts due or to become due the Contractor. The performance of such emergency work shall in no way relieve the Contractor of responsibility for damages which may occur during or after such precaution has been duly taken.

GC-36 ASSIGNMENT AND SUBLETTING OF CONTRACT

In case the Contractor assigns all, or any part, of the monies due or to become due under this Contract, the instrument of assignment shall contain a clause substantially to the effect that it is agreed that the right of the assignee in and to any monies due or to become due the Contractor shall be subject to all prior claims of all persons, firms and corporations for services rendered or materials supplied for the performance of the Work called for in this Contract and that no money shall be paid assignee on behalf of the Contractor by the City until such time as the Contractor has discharged its obligations to the City under the Contract. It is expressly understood and agreed that no assignment shall be effective as against the City unless it complies with the foregoing.

The Contractor shall not award subcontracts which total more than sixty percent (60%)

of the total Contract Price based upon the unit prices within the Bid submitted to the City by the Contractor and shall self-perform not less than forty percent (40%) of the total Contract Price based upon the unit prices within the Bid submitted to the City by the Contractor. Should any Subcontractor fail to perform in a satisfactory manner, the Work undertaken by such Subcontractor shall be immediately terminated by the Contractor. The Contractor shall be as fully responsible to the City for the acts and omissions of its Subcontractors, and of persons either directly or indirectly employed by them, as Contractor is for the acts and omissions of persons directly employed by it. Approval by the City of any Subcontractor shall not constitute a waiver of any right of the City to reject Defective Work, material or equipment not in compliance with the requirements of the Contract Documents. The Contractor shall not make any substitution for any Subcontractor accepted by the City unless the City so agrees in writing.

The Contractor shall cause appropriate provisions to be inserted in all subcontracts relative to the Work to bind Subcontractors to the Contractor by the terms of the Contract Documents insofar as applicable to the Work of the Subcontractor and to give the Contractor the same power to terminate any subcontract as the City has to terminate the Contractor under any provisions of the Contract Documents.

Nothing contained in the Contract Documents shall create any contractual relationship between any Subcontractor and the City, nor shall anything contained in the Contract Documents create any obligation on the part of the City to pay to or to see to the payment of any sums due any Subcontractor.

Prior to the City's approval of the Contract Bid, the successful Bidder shall submit to the City Engineer or the City's designated representative for City acceptance a list of the names of all Subcontractors proposed for portions of the Work and shall designate which Work each is to perform.

The City Engineer or the City's designated representative shall, prior to City's approval of the Contract Bid, notify the successful Bidder, in writing, if the City, after due investigation, has reasonable objection to any Subcontractor on such list, and the Contractor shall substitute a Subcontractor acceptable to the City at no additional cost to the City or shall be allowed to withdraw its Bid, and the City shall either rebid the Project or accept the next best lowest and responsible Bidder. The failure of the City to make objection to a Subcontractor shall constitute an acceptance of such Subcontractor but shall not constitute a waiver of any right of the City to reject Defective Work, material or equipment not in conformance with the requirements of the Contract Documents.

The Contractor shall not make any substitution for any Subcontractor who has been accepted by the City unless the City Engineer or the City's designated representative determines that there is a good cause for doing so. The City's disapproval of any Subcontractor shall not, under any circumstance, be the basis for an increase in the Contract Price or a claim for delay damages.

GC-37 DISPUTE RESOLUTION

City and Contractor agree that disputes relative to the Work shall first be addressed by negotiations between the parties. If direct negotiations fail to resolve the dispute, the party initiating the claim that is the basis for the dispute shall be free to take such steps as it deems necessary to protect its interests; provided, however, that notwithstanding any such dispute Contractor shall proceed with the Work as per the Contract Documents as if no dispute existed; and provided further that no dispute will be submitted to arbitration without the City's express written consent.

In order to preserve its rights to dispute a matter hereunder, the complaining party must submit a written notice to the other party setting forth the basis for its complaint within twenty (20) calendar days following receipt of the decision of the Consulting Engineer as to such matter as per Article GC-39. No dispute resolution shall be a condition precedent to any legal action.

GC-38 INSURANCE

The Contractor shall secure and maintain through the duration of this Contract insurance (on an occurrence basis unless otherwise agreed to) of such types and in such amounts (but not less than the amounts set forth in Section IB-8 of the Instructions to Bidders) as may be necessary to protect the Contractor and the City and agents of the City against all hazards or risks of Loss as hereinafter specified. The form and limits of such insurance, together with the underwriter thereof in each case, shall be approved by the City, but regardless of such approval it shall be the responsibility of the Contractor to maintain adequate insurance coverage at all times. Failure of the Contractor to maintain adequate coverage shall not relieve it of any contractual responsibility or obligation, including, but not limited to, the indemnification obligation.

Satisfactory certificates of insurance shall be filed with the City prior to Contractor's starting any construction work on this Contract. The certificates shall state that thirty (30) days written notice will be given to the City before any policy covered thereby is changed or cancelled. Failure by the Contractor to furnish the required insurance within the time specified in the Notice of Award of the Contract by the City may, at the City's option, be the basis for the City's exercising its right to terminate the Contract pursuant to Article GC-42.

(a) Commercial General Liability - This insurance shall protect the Contractor against all claims arising from the injuries to members of the public or damage to property of others arising out of any act or omission of the Contractor or its agents, employees or Subcontractors. In addition, this policy shall specifically insure the contractual liability assumed by the Contractor under Article GC-33.

The liability limits shall be as stated in the Instructions to Bidders or in the Project Special Provisions.

(b) Automobile Liability - This insurance shall protect the Contractor against all claims for injuries to members of the public and damage to property of others arising from the use of motor vehicles, and shall cover operation on and off the site of all motor vehicles licensed for highway use, whether they are owned, non-owned or hired.

The liability limits shall be as stated in the Instructions to Bidders or in the Project Special Provisions.

(c) Worker's Compensation and Employer's Liability - This insurance shall protect the Contractor against all claims under applicable state worker's compensation laws. The Contractor shall also be protected against claims for injury, disease or death of employees which, for any reason, may not fall within the provisions of a worker's compensation law. This policy shall include an "all states" endorsement.

The liability limits shall be as stated in the Instructions to Bidders or in the Project Special Provisions.

(d) Additional Insurance -

- (1) The Contractor shall be required to purchase an Owner's Protective Liability Insurance Policy, issued on an occurrence basis and covering bodily injury (and death) and property damage, naming the City as named insured. The liability limits shall be as stated in the Instructions to Bidders or in the Project Special Provisions. The original policy shall be placed on file with the City and maintained during the life of the Contract. Such policy shall contain no exclusion relative to any function performed by the City or its employees and agents in connection with the Work.
 - (2) Additional insurance covering special hazards may be required on certain projects. Such additional insurance requirements shall be as specified in Instructions to Bidders or Project Special Provisions.
- (e) Subcontractors' Insurance - If a part of the Contract is to be sublet, the Contractor shall either:
- (1) Cover all Subcontractors in its insurance policies; or
 - (2) Require each Subcontractor not so covered to secure insurance which will protect Subcontractor and the City against all applicable hazards or risks of loss as and in the minimum amounts designated for the Contractor.

GC-39 AUTHORITY AND DUTY OF THE CONSULTING ENGINEER

Unless the City acts as its own Consulting Engineer, the Consulting Engineer is an independent contractor. It is mutually agreed by and between the parties to this Contract that the Consulting Engineer shall observe and inspect all Work included herein (provided, however, that any such observations and inspections shall not alter the rights, responsibilities and obligations of the parties as set forth in Article GC-22). Anything in the Contract Documents to the contrary notwithstanding, in order to prevent delays and disputes, it is further agreed by and between the parties to this Contract that the Consulting Engineer shall in all cases determine the amount and quantities of the several kinds of Work which are to be paid for under this Contract; that Consulting Engineer shall determine all questions relating to the Plans and Specifications for the Project; that Consulting Engineer shall issue promptly any written clarifications or interpretations of the requirements of the Contract Documents (in the form of drawings or otherwise) which Consulting Engineer may determine are necessary, which shall be consistent with or reasonably inferable from the overall intent of the Contract Documents; that Consulting Engineer's decisions and findings shall be a condition precedent to the right of the parties to submit any proper matter and to any rights of the Contractor to receive any money under this Contract; provided, however, that should the Consulting Engineer render any decision or give any direction which, in the opinion of either party hereto, is not in accordance with the meaning and intent of this Contract, either party may file with the other, within twenty (20) days a written objection to the decision or direction so rendered and, by such action, may reserve the right to submit the question so raised as herein provided, except as otherwise provided in Article GC-37. It is the intent of the Contract that there shall be no delay in the execution of the Work, and the decisions or directions of the Consulting Engineer as rendered shall be promptly carried out.

GC-40 CORRECTION OF LABOR, ETC. - BEFORE FINAL PAYMENT

At Consulting Engineer's request, Contractor shall, at Contractor's expense, promptly remove from the job site all labor, supplies, materials, equipment and/or other facilities condemned by Consulting Engineer as not in accordance with the Contract Documents, whether incorporated or not; and the Contractor shall, at Contractor's expense, promptly replace and re-execute all labor, supplies, materials, equipment and/or other facilities in accordance therewith and, at Contractor's expense, restore all Work of other Contractors and Subcontractors destroyed or damaged as a result of such removal, replacement and re-execution.

GC-41 CORRECTION OF LABOR, ETC. - AFTER FINAL PAYMENT

(a) Contractor guarantees to City that all Work performed under this Contract shall be free from defects in material or workmanship for a period of not less than two (2) full years from the date of final payment by City; provided, however, that whenever any provision of the Contract Documents requires a guarantee for a period in excess of two (2) years to be furnished by Contractor, Contractor shall promptly execute same in writing and shall promptly deliver same to City.

(b) Contractor shall promptly procure from each Subcontractor a written guarantee that all Work performed by such Subcontractor shall be free from defects in material or workmanship for a period of not less than two full (2) years from the date of final payment by City to Contractor and shall promptly deliver same to City; provided, however, that wherever any provision of the Contract Documents requires a guarantee for a period in excess of two (2) years to be furnished by a Subcontractor, Contractor shall promptly procure same in writing from the appropriate Subcontractor and shall promptly deliver same to City.

(c) Whenever any provision of the Contract Documents requires a guarantee for a period in excess of two (2) years, but does not specify who is to give such a guarantee, it shall be given by the Contractor regardless of who is performing the Work for which the guarantee is required. All such guarantees shall be in writing and shall be promptly delivered to City.

(d) The furnishing of guarantees by Subcontractors and materialmen shall not relieve Contractor of its obligations under guarantees required of Contractor under the Contract Documents. In addition to the above guarantees, Contractor will (1) obtain and assign to City all available manufacturers and suppliers warranties; and (2) at City's sole option, assign to City any rights Contractor may have against any Subcontractor and/or supplier for Defective Work, materials or equipment.

(e) Any provision of the Contract Documents to the contrary notwithstanding, all guarantees provided for in the Contract Documents shall begin to run from the date of final payment by City to Contractor.

(f) Neither the issuance of the final certificate, payment nor any provision in the Contract Documents shall relieve the Contractor of responsibility for Work determined by City not to be in accordance with the Contract Documents. If, within two (2) years of the date of final payment to Contractor or within any longer period of time as may be prescribed by applicable law or by the terms of any applicable special warranty required by the Contract Documents, any of the Work is found by City to be defective or not in conformance with the Contract Documents then, at City's request, Contractor shall, at Contractor's expense, promptly remove from the premises all Work determined by the City to be defective or not in accordance with the Contract

Documents; and Contractor shall, at Contractor's expense, promptly replace and re-execute all Work in accordance therewith and, at Contractor's expense, restore all Subcontractors' Work and Work of other Contractors and Subcontractors damaged as a result of such removal, replacement and re-execution. City shall with reasonable promptness give notice of any Work condemned by City as not in accordance with the Contract Documents. If, within ten (10) days after the mailing of such notice, the Contractor shall fail or neglect to make, or undertake to make, with due diligence any required repairs or corrections, the City shall make such repairs at Contractor's expense; provided, however, that, in case of an emergency which, in the judgment of City, would cause serious loss, hazard or damage if not corrected immediately, such repairs may be made without prior notice being sent to the Contractor, and Contractor shall nevertheless be liable to the City for the cost thereof.

GC-42 RIGHT OF CITY TO TERMINATE CONTRACT

Without in any manner limiting the right of the City to terminate the Contract or declare the Contractor in default thereof for any reason set forth in the Contract Documents, if the Work to be done under this Contract shall be abandoned by the Contractor; or if this Contract shall be assigned by Contractor otherwise than as herein provided; or if the Contractor should be judged as bankrupt; or if a general assignment of its assets should be made for the benefit of its creditors; or if a receiver should be appointed for the Contractor or any of its property; or if at any time the Consulting Engineer shall certify in writing to the City that the performance of the Work under this Contract is being unnecessarily delayed, that the Contractor is violating any of the conditions or covenants of this Contract or the Specifications therefore, that it is executing the same in bad faith or otherwise not in accordance with the terms of said Contract; or if all Bid items of the Project are not completed within the time named for their completion or within the time to which such completion date may be extended; then, in addition to other rights the City may choose to exercise, the City may, at its option, serve written notice upon the Contractor and its surety of City's intention to terminate this Contract, and, unless within five (5) days after the serving of such notice upon the Contractor, a satisfactory arrangement be made for the continuance thereof, this Contract shall cease and terminate. In the event of such termination, the City shall immediately serve notice thereof upon the surety and the Contractor, and the surety shall have the right to take over and complete the Work; provided, however, that if the surety does not commence performance thereof within thirty (30) days from the date of said notice of termination, the City may take over the Work and prosecute same to completion, by contract or otherwise, for the amount and at the expense of the Contractor, and the Contractor and its surety shall be liable to the City for any and all excess cost sustained by the City by reason of such prosecution and completion; and in such event the City may take possession of, and utilize in completing the Work, all such materials, equipment, tools and plant as may be on the site of the Work and necessary therefore. When Contractor's services have been so terminated, such termination shall not affect any rights or remedies of City against Contractor then existing or which may later accrue. Similarly, any retention or payment of monies due Contractor shall not release Contractor from liability.

City reserves the right, in its sole discretion and for its convenience and without cause or default on the part of Contractor, to terminate the Contract by providing written notice of such termination to Contractor. Upon receipt of such notice from City, Contractor shall: (1) immediately cease all Work; or (2) meet with City and, subject to City's approval, determine what Work shall be required of Contractor in order to bring the Project to a reasonable termination in accordance with the request of City. If City shall terminate for its convenience as herein provided, City shall: (1) compensate Contractor for all purchased materials and actual cost of Work completed to date of termination; and (2) release and indemnify Contractor against any liability Contractor may have to any third parties as the result of any contracts, commitments, purchase orders or any other such liabilities Contractor may have incurred as a

result of its obligations under the provisions of the Contract. Contractor agrees that it shall minimize such potential liabilities by, where practical, informing third parties of City's right to terminate and attempting to obtain from such third parties a waiver of any liability in the event of such termination.

Any termination of the Contract for alleged default by Contractor that is ultimately determined to be unjustified shall automatically be deemed a termination for convenience of the City.

GC-43 CITY'S RIGHT TO DO WORK

Without otherwise limiting City's rights under the Contract Documents, if Contractor should neglect to prosecute the Work properly or fail to perform any provision of the Contract Documents, City, after three (3) days' written notice to Contractor may, without prejudice to any other remedy it may have, make good such deficiencies and may deduct the cost thereof from the payment then or thereafter due Contractor.

GC-44 PAYMENTS

(a) Before the first application for payment, the Contractor shall submit to the Consulting Engineer a schedule of values allocated to the various portions of the Work, prepared in such form and supported by such data to substantiate its accuracy as the Consulting Engineer may require. This schedule, unless objected to by the Consulting Engineer, shall be used only as a basis for the Contractor's applications for payment and does not constitute approval by the Consulting Engineer of the method or performance by the Contractor.

(b) Payment will be made to Contractor monthly from funds available within thirty (30) days of the City's receipt of a proper undisputed pay request from the Contractor on the basis of a duly certified estimate of the value of all labor and materials delivered on the site and accepted by the Consulting Engineer during the preceding month, calculated in proportion to the Contract Price, but to ensure the proper performance of the Contract, ten percent (10%) of the amount of each estimate will be retained until final completion and acceptance of all Work covered by the Contract.

(c) Each payment made to the Contractor shall be on account of the total amount payable to the Contractor by or for the City, and all materials and Work covered by the partial payments made shall therefore become the sole property of the City. This provision shall not be construed as relieving the Contractor from the responsibility imposed by the Contract Documents for the care and protection of materials and Work upon which payments have been made, for the restoration of any damaged Work, or as a waiver of the right of the City to require the fulfillment of all the terms of the Contract. Progress payments in respect to materials will be made only for materials delivered on the site and accepted by the Consulting Engineer, all calculated in proportion to the Contract Price.

(d) In general, no allowance will be made in estimates for materials delivered on the site and not incorporated in the Work except in case of those items considered by the Consulting Engineer to be major items of considerable magnitude, which will be allowed in estimates on the basis of ninety percent (90%) of invoices, the value calculated in proportion to the Contract Price.

(e) The retained percentages herein provided for are to be retained and held for the sole protection and benefit of the City, and no other person, firm or corporation shall have or

assert any lien, claim, right or priority therein, thereon or thereto, or be entitled to receive any part thereof, except as herein expressly provided.

(f) The City shall require at intervals as it shall determine and at any time before final payment is made for the Work specified herein that the Contractor furnish the City with written acknowledgments (to the extent of payment made) by all Subcontractors and vendors who have done work or labor on, or who have furnished materials for, this Project that they have been fully paid in whole or in part by the Contractor for such work or labor done or materials furnished by them. Contractor's failure to furnish said list or to include all such Subcontractors and vendors shall not relieve Contractor or its surety of any obligation assumed under this Contract, nor shall the City's request for such list create any obligation on City's part to verify accuracy. City may require, at its option, lien waivers on forms supplied by City.

(g) The Contractor has, per the Instructions to Bidders, Bid this job net of all sales and compensation taxes. No application for payment shall include any amount for reimbursement of such taxes paid by Contractor resulting from Contractor's failure to use the Project Exemption Certificate for any purchase in connection with the Work. Final payment will not be made to Contractor until the City has received the Project Completion Certification from the Contractor along with a Consent of Surety to Final Payment.

(h) The Contractor shall be responsible for the return and/or exchange of surplus materials, and all credits for returned or exchanged materials shall be first submitted to the Consulting Engineer for approval. Applications for payment shall reflect any such credits, and the Contract Price shall be adjusted as necessary to reflect such credits. Non-returnable excess materials shall be turned over to the City, or, at its option, be removed from the Project site at Contractor's expense.

(i) The acceptance by the Contractor of final payment shall be and shall operate as a release to the City of all claims and all liability to the Contractor other than written claims in stated amounts as may be specifically excepted by the Contractor for all things done or furnished in connection with this Contract and for every act and neglect of the City and others relating to or arising out of this Contract. Any payment, however, final or otherwise, shall not release the Contractor or its sureties from any obligations under the Contract Documents, the Bonds, or insurance coverage's.

GC-45 PAYMENTS WITHHELD

City may withhold or, on account of subsequently discovered evidence, nullify the whole or a part of any application for payment to the extent necessary to protect City from loss on account of:

- (a) Incomplete Work or Defective Work not remedied;
- (b) A reasonable doubt that the Work can be completed for the balance of the Contract Price then unpaid;
- (c) Damage to City; or
- (d) A breach of this Contract.

GC-46 LIQUIDATED DAMAGES

It is mutually understood and agreed by and between the parties to this Contract that time is of the essence of this Contract, and that in the event that the Contractor shall fail in the performance of the Work specified and required to be performed within the period of time stipulated therefore in the Contract, after due allowance for any extension or extensions of time which may be granted under the Contract, the said Contractor shall pay to City, as stipulated liquidated damages and not as a penalty, the sum stipulated herein for each and every day that the Contractor shall be in default.

In the case of joint responsibility for any delay in the final completion of the Work covered by this Contract, where two or more separate contracts are in force at the same time and cover work on the same project and at the same site, the total amount of liquidated damages assessed against all contractors under such contracts, for any one day of delay in the final completion of the Work will not be greater than the approximate total of the damages sustained by the City by reason of such delay in completion of the Work as set forth in the table below, and the amount assessed against any one contractor for such one day of delay will be based upon the individual responsibility of such contractor for the aforesaid delay as determined by, and in the judgment of, the City.

In case of failure on the part of the Contractor to effect completion within the time specified, the City shall have the right to deduct from the total compensation otherwise due the Contractor as liquidated damages based on the full Bid price of the Contract, fixed and agreed to in advance, an amount according to the following schedule:

<u>Contract Amount</u>			<u>Liquidated Damages</u>
\$0	to	\$50,000	\$250.00
\$50,000	to	\$100,000	\$400.00
\$100,000	to	\$500,000	\$800.00
\$500,000	to	\$1,000,000	\$1,000.00
\$1,000,000	to	\$2,000,000	\$1,750.00
\$2,000,000	to	\$5,000,000	\$2,500.00
\$5,000,000	to	\$10,000,000	\$3,500.00
\$10,000,000	to	\$20,000,000	\$5,500.00
\$20,000,000	and up		\$6,000.00

for each twenty-four (24) hour calendar day, including weekends and holidays, the Work remains incomplete over the specified completion time. **(THE CITY RESERVES THE RIGHT TO ADJUST THE SCHEDULE OF LIQUIDATED DAMAGES, PRIOR TO ADVERTISING FOR BIDS, BASED ON THE SCOPE AND URGENCY OF THE PROJECT.)**

The City shall have the right to deduct said liquidated damages from any moneys in its hands, otherwise due or to come due, to the Contractor, or to sue for and recover compensation for damages for nonperformance of this Contract.

GC-47 BONDS

Contractor shall after Notice of Award furnish City the Performance, Maintenance, and Statutory or Labor and Material Payment Bond as required by the Instructions to Bidders. Failure to furnish such Bonds within the time specified in the Notice of Award may, at the City's option, be the basis for declaring Contractor in default and pursuing such legal rights as the City deems in its best interest, including, but not limited to, enforcement of the City's rights as to Bid security.

GC-48 EASEMENTS AND RIGHTS-OF-WAY

Permanent and temporary (construction) easements and rights-of-way will be provided by the City as shown on the Plans. The Contractor shall confine its operations to the easements provided and shall carefully note where buildings, structures or other obstructions will limit its working space. In the event that easements and rights-of-way are not available or if they have not been secured, or if entry to property is denied by court order, injunction, litigation or any other reason, the Contractor shall cease operations in such area and confine its Work to other areas approved by the City. In the event of any delay arising from delays in securing easements and rights-of-way, the Contractor shall have no claim against the City for damages arising from such delay but may request an extension of time under Article GC-27.

GC-49 UNDERGROUND FACILITIES AND UTILITIES

Underground Facilities and utilities, including sewer, water, gas, sprinkler systems, etc. damaged by the Contractor within or outside the right-of-way shall be restored at the Contractor's expense and at no cost to the City. The Contractor shall make every effort to locate these lines and protect them.

GC-50 USE OF PREMISES

(a) Contractor shall confine its operations to limits indicated by law, ordinances, rules, regulations, permits of City or directions of Consulting Engineer and shall not unreasonably encumber the premises and/or site.

(b) Contractor shall not load or permit any part of any structure, streets or highways to be loaded with a weight that exceeds load limits which will endanger their safety.

(c) Contractor shall comply with federal, state and local laws and ordinances, as well as any specific instructions regarding signs, advertisements, fires and smoking from Consulting Engineer.

(d) A laydown area or staging area will be provided at the site and shall be chosen by Consulting Engineer. Contractor will furnish its own weather protection if required.

(e) No City equipment will be taken out of service or put into service without approval of City.

GC-51 ALLOWANCES

Contractor agrees that the Contract Price includes all allowances required by the Contract Documents. Contractor declares that the Contract Price includes all other sums for expenses and overhead and fee on account of allowances as it deems proper. No demand for expenses or overhead and fee other than those included in the Contract Price shall be allowed.

GC-52 CUTTING, PATCHING AND DIGGING

(a) Contractor shall do all cutting, fitting or patching of its Work that may be required to make its several parts come together properly and fit it to receive or be received by Work of others shown upon or reasonably implied by the Contract Documents.

(b) Contractor shall not endanger any property of City or any other individual or entity, or the Work by cutting, digging or otherwise and shall not cut or alter the work of others except with the written consent of City.

(c) Contractor shall assume responsibility for the patching or repairs, by the proper trade, of damages caused by Work under this Contract.

(d) Contractor shall comply with all local ordinances dealing with cutting, patching and digging and shall obtain all necessary permits.

GC-53 CLEANING UP

Contractor shall at all times keep the premises/site free from accumulations of waste material or rubbish caused by its employees or Work; and at the completion of the daily Work it shall remove all its rubbish from and about the premises/site and all its tools, scaffolding and surplus materials, and shall leave its Work "broom clean" or its equivalent unless more exactly specified. In case of dispute, City may remove the rubbish and charge the cost to Contractor.

GC-54 TEMPORARY FACILITIES

(a) Except where special permission has been granted by City to use existing toilet facilities belonging to City, Contractor shall provide and maintain sanitary temporary toilet facilities located where directed by Consulting Engineer for accommodation of all persons engaged on the Work. Sanitary facilities shall be of reasonable capacity, properly maintained throughout the construction period, and obscured from public view to the greatest practical extent. If toilets of the chemically treated type are used, at least one toilet will be furnished for each twenty workers. Contractor shall enforce the use of such sanitary facilities by all personnel at the site.

Temporary toilets shall be enclosed and weatherproof and kept in sanitary and approved condition at all times. After use for same has ceased, Contractor shall remove the temporary toilet facilities from City's premises and disinfect and fill any vaults.

(b) Contractor shall provide and maintain any necessary temporary offices, storerooms, roadways, etc., as may be required for its Work. Same shall be located and constructed in an approved manner acceptable to Consulting Engineer. Upon completion of Work or when requested by Consulting Engineer, Contractor shall remove same from City's premises and leave the area in a clean and orderly condition.

(c) Contractor shall provide and maintain temporary heat as required to protect all Work and material against injury from dampness and/or cold to the satisfaction of Consulting Engineer.

(d) Unless otherwise specified in the Contract Documents, Contractor shall provide, at its cost and expense, temporary power, wiring and lights from City's provided source as may be required for its operations.

GC-55 SANITARY REGULATIONS AND WATER

The operations of the Contractor shall be in full conformity with all of the rules and regulations of boards and bodies having jurisdiction with respect to sanitation. The Contractor shall supply safe and sufficient drinking water to all of its employees. The Contractor shall obey

and enforce all sanitary regulations and orders, and shall take precautions against infectious diseases and the spread of same.

All water used in the course of the Work shall be hauled in or purchased from the local water company's distribution system at the Contractor's own cost and expense.

GC-56 COMPLIANCE WITH LAWS

The Contractor shall be fully familiar with all City, county, state and federal laws, ordinances or regulations which would in any way control the actions or operations of those engaged in the Work under this Contract or which would affect the materials supplied to or by them. It shall at all times observe and comply with all ordinances, laws and regulations and shall protect and indemnify and defend the City and the City's officers and agents against any claims or liability arising from or based on any violation of same.

GC-57 UNFAVORABLE CONSTRUCTION CONDITIONS

During unfavorable weather, or other unfavorable conditions for construction operations, the Contractor shall pursue only such portions of the Work as will not be damaged thereby. No portions of the Work, the satisfactory quality or efficiency of which will be affected by any unfavorable conditions, shall be constructed while these conditions exist, unless, by special means or precautions approved by the Consulting Engineer, the Contractor shall be able to perform the Work in a proper and satisfactory manner.

GC-58 CONTRACTOR'S RISK

The Contractor shall assume full responsibility for the Work and shall bear any loss and repair any damage at his/her own cost occasioned by neglect, accident, vandalism or natural cause, whether foreseen or unforeseen, during the progress of the Work and until the Work is completed and accepted by the City.

GC-59 SAFETY RULES

(a) Contractor shall be responsible for enforcing safety rules to ensure protection of the employees and property of City, to assure uninterrupted production and to assure safe working conditions for Contractor and Subcontractors and their employees and to assure the safety of the general public. In addition to any other rights the City might exercise, Contractor and/or any Subcontractor failing to follow safety rules shall be subject to eviction from the job site and may be refused reentry.

(b) Contractor is expected to establish and enforce a comprehensive safety program on this Project for the protection of its personnel, its Subcontractors' personnel, City's employees and all other persons exposed to hazards resulting from Contractor's operations. As a minimum requirement, Contractor shall review and discuss the details of its program with Consulting Engineer at the first project meeting. The items to be covered shall include, but not necessarily be limited to,

- (1) Personal protective equipment;
- (2) First aid - personnel and facilities;
- (3) Arrangements for medical attention;
- (4) Sanitary facilities;
- (5) Fire protection;
- (6) Signs, signals and barricades;

- (7) Security regulations;
- (8) Safety inspections;
- (9) Designation of persons responsible for the program;
- (10) Reporting forms and procedures;
- (11) Material handling and storage;
- (12) Lines of communication;
- (13) Determination of potential hazards;
- (14) Personnel safety meetings and education;
- (15) Access to work areas;
- (16) Subcontractors involvement in the program;
- (17) Inspections and corrective action.

Contractor is fully responsible for the safety program and any and all methods and procedures provided for therein whether or not City or Consulting Engineer shall have reviewed and/or accepted such program.

GC-60 WEEKENDS, HOLIDAY AND NIGHT WORK

No Work shall be done between the hours of 6:00 p.m. and 7:00 a.m., nor on weekends or City holidays, without the written approval or permission of the City forty-eight (48) hours in advance in each case, except such Work as may be necessary for the proper care, maintenance and protection of Work already done or of equipment, or in the case of an emergency.

Night Work may be established by the Contractor, as a regular procedure, with the written permission of the City; such permission, however, may be revoked at any time by the City.

GC-61 APPROVAL OF EQUALS

"Approved Equals," where permitted by the Contract Documents or otherwise made feasible by market conditions, shall be considered for approval as follows:

(a) Contractor shall notify City in writing if it wishes to use an approved equal specifically named in the Contract Documents.

(b) If Contractor desires to use an "equal" not specifically named in the Contract Documents, it must first inform City and receive written approval for such substitutions. City has no obligation to approve such request and is not responsible for any delay or cost incurred caused by Contractor's making such request.

The Contractor shall be solely responsible for design risks, delays and other claims arising out of any approved alternates.

GC-62 TEST OF MATERIALS OFFERED BY CONTRACTOR

All specified and required tests for approval of material shall be made at the expense of the Contractor by a properly equipped laboratory of established reputation, whose work and testing facilities shall be approved by the Consulting Engineer. Approval of materials based on acceptable tests will apply only while such materials as furnished equal or exceed the tested samples or test specimens in quality and minimum requirements. Any change in origin, method of preparation or manufacture of such materials will require new tests and approval thereof.

Reports of all tests shall be furnished to the Consulting Engineer in as many certified counterparts as may be required by the Consulting Engineer.

GC-63 TESTING OF COMPLETED WORK

Before Final Acceptance, all installed and constructed equipment, devices and other work which is to be tested under the Contract Documents shall be tested and each part shall be in good condition and working order or shall be placed in such condition and order at the expense of the Contractor. All tests of such completed Work required under this Contract shall be made under the direction of the Consulting Engineer.

GC-64 BORROW AND WASTE AREAS

All borrow materials shall be obtained by the Contractor at its own cost and expense. The borrow area and materials shall be approved by the Consulting Engineer and shall be friable material suitable for compaction.

All waste areas shall be located off the site and arrangements and payment for use of such areas shall be the sole responsibility of the Contractor. All waste disposal shall be in compliance with federal, state and local laws, ordinances and regulations.

GC-65 PARKING AREAS, DRIVES AND WALKS

All existing parking areas, drives and walks within the Project limits shall be adjusted to conform to the lines and grades shown on the Plans. Any of the above structures that are removed or damaged during construction shall be reconstructed at Contractor's expense of materials that will create a quality equal to or better than the condition of the existing facility prior to construction operation.

GC-66 STREET SIGNS AND TRAFFIC AIDS

The Contractor shall be responsible for all preexisting traffic control devices at the Project site, including installation, maintenance, removal and storage of such devices. All temporary and permanent traffic control devices supplied by the Contractor shall comply with and be installed in accordance with the Manual on Uniform Traffic Control Devices, current edition as revised, and the Traffic Control Devices Handbook.

GC-67 PLACING WORK IN SERVICE/PARTIAL UTILIZATION

If desired by the City, portions of the Work may be placed in service when completed for Partial Utilization by the City, and the Contractor shall give proper access to the Work for this purpose; but such use and operation shall not constitute an acceptance of the Work, and the Contractor shall be liable for defects due to faulty construction until the entire Work under this Contract is finally accepted and for such periods of time as designated in the Contract Documents or otherwise permitted by law.

GC-68 NON-DISCRIMINATION/OTHER LAWS

- (a) The Contractor agrees that:
 - (1) The Contractor shall observe the provisions of the Kansas Act Against Discrimination and shall not discriminate against any person in the

performance of work under the present contract because of race, religion, color, sex, disability, national origin, ancestry or age;

- (2) In all solicitations or advertisements for employees, the Contractor shall include the phrase, "equal opportunity employer," or a similar phrase to be approved by the Kansas Human Rights Commission ("Commission");
- (3) If the Contractor fails to comply with the manner in which the Contractor reports to the Commission in accordance with the provisions of K.S.A. 44-1031 and amendments thereto, the Contractor shall be deemed to have breached the present Contract and it may be cancelled, terminated or suspended, in whole or in part, by the City;
- (4) If the Contractor is found guilty of a violation of the Kansas Act Against Discrimination under a decision or order of the Commission which has become final, the Contractor shall be deemed to have breached the present contract and it may be cancelled, terminated or suspended, in whole or in part, by the City; and
- (5) The Contractor shall include the provisions of Subsections (1) through (4) in every subcontract or purchase order so that such provisions will be binding upon such Subcontractor or vendor.

The provisions of this Article shall not apply to a contract entered into by a Contractor:

- (A) Who employs fewer than four employees during the term of such contract; or
 - (B) Whose contracts with the City cumulatively total \$5,000 or less during the fiscal year of the City.
- (b) The Contractor further agrees that the Contractor shall abide by the Kansas Age Discrimination In Employment Act (K.S.A. 44-1111 et seq.) and the applicable provision of the Americans With Disabilities Act (42 U.S.C. 12101 et seq.) as well as all other federal, state and local laws, ordinances and regulations applicable to this Project and to furnish any certification required by any federal, state or local governmental agency in connection therewith.

GC-69 FEDERAL LOBBYING ACTIVITIES

31 USCS Section 1352 requires all subgrantees, contractors, subcontractors and consultants who receive federal funds via the City to certify that they will not use federal funds to pay any person for influencing or attempting to influence a federal agency or Congress in connection with the award of any federal contract, grant, loan or cooperative agreements.

In addition, contract applicants, recipients and subrecipients must file a form disclosing any expenditures they make for lobbying out of non-federal funds during the Contract period.

Necessary forms are available from the City Engineer and must be returned to the City with other Contract Documents. It is the responsibility of the general Contractor to obtain executed forms from any Subcontractors who fall within the provisions of the Code and to provide the City with the same.

GC-70 RECORDS

Contractor shall maintain copies of records pertaining to the construction of this Project for a period of five (5) years from the date of final payment. Such records shall be made available to the City for audit and review purposes upon written request therefor from City or its authorized agent(s) during the construction period and the five (5) year period following final payment.

GC-71 TITLES, SUBHEADS AND CAPITALIZATION

Titles and subheadings as used herein and other Contract Documents are provided only as a matter of convenience and shall have no legal bearing on the interpretation of any provision of the Contract Documents. Some terms are capitalized throughout the Contract Documents, but the use of or failure to use capitals shall have no legal bearing on the interpretation of such terms.

GC-72 NO WAIVER OF RIGHTS

No waiver of any breach of this Contract shall be construed to be a waiver of any other or subsequent breach.

GC-73 SEVERABILITY

The parties agree that should any provision of the Contract Documents be determined to be void, invalid, unenforceable or illegal for whatever reason such provision(s) shall be null and void but that the remaining provisions of the Contract Documents shall be unaffected thereby and shall continue to be valid and enforceable.

GC-74 GOVERNING LAW

This Agreement shall be governed by, and construed in accordance with, the laws of the State of Kansas.

GC-75 VENUE

Venue of any litigation arising in connection with this Agreement shall be the State courts of Johnson County, Kansas.

CITY OF MISSION
2017 STORM SEWER POINT REPAIRS, CONTRACT 1
PROJECT SPECIAL CONDITIONS

TABLE OF CONTENTS

<u>ARTICLE</u>	<u>SUBJECT</u>	<u>PAGE</u>
SC-1.	SCOPE OF WORK	1
SC-2.	CONTRACT SPECIFICATIONS.....	1
SC-3.	STANDARD SPECIFICATIONS.....	1
SC-4.	CONTRACT DRAWINGS.....	1
SC-5.	MEASUREMENT AND PAYMENT.....	1
SC-6.	MOBILIZATION OF EQUIPMENT	4
SC-7.	INSPECTION OF WORK.....	4
SC-8.	BRACING AND SHORING	5
SC-9.	TRENCH BACKFILL.....	5
SC-10.	SAMPLING AND TESTING	5
SC-11.	TRAFFIC SAFETY.....	5
SC-12.	NOTIFICATION OF PROPERTY OWNERS.....	5
SC-13.	TREE AND PLANT PROTECTION	5
SC-14.	WEEDS.....	6
SC-15.	RESTORATION	6
SC-16.	UTILITY MEETINGS AND UTILITY ADJUSTMENT	7
SC-17.	WATER POLLUTION CONTROL	7
SC-18.	RIGHT-OF-WAY	8
SC-19.	CONSTRUCTION TIMELINE AND LIMITATIONS	8

CITY OF MISSION

2017 STORM SEWER POINT REPAIRS, CONTRACT 1

PROJECT SPECIAL CONDITIONS

SC-1. SCOPE OF WORK

The work provided for in these Specifications shall consist of furnishing all labor, materials, appliances, and equipment, and performing all work and operations in connection with the construction of items and all other incidental and related work as set forth in these Specifications and as directed by the Engineer to make a complete and finished job.

SC-2. CONTRACT SPECIFICATIONS

The Specifications that shall govern the materials furnished and work performed in the construction of the work covered by the Contract or Contracts based thereon, are divided, classified, designated, and arranged as shown in the PROJECT SPECIAL CONDITIONS, TABLE OF CONTENTS attached hereto. No attempt has been made in the foregoing designated Specifications to segregate work to be performed by any trade, subcontract, or proposal item, under any one specification. Any segregation between trade or craft jurisdiction limits, and the establishment of subcontract limits, will be solely a matter of agreement between the Contractor and his employees and his subcontractors. The Specifications will govern the construction of the entire work, and the provisions thereof will govern each item and unit of work to which such provisions apply.

When reference is made to Engineer, it shall have the same meaning as consulting engineer as set forth in Paragraph GC-2 of the General Conditions.

SC-3. STANDARD SPECIFICATIONS

The work shall conform to these Specifications and to the "Standard Specifications" where reference is made herein. Where reference is made in the Specifications and Contract Documents to "Standard Specifications," it shall mean that the reference is made to the current edition of the Standard Specifications for State Road and Bridge Construction, Kansas Department of Transportation, current edition of City of Mission Traffic Signal Specifications, current edition of the Manual On Uniform Traffic Control Devices, and The City of Mission Traffic Control Handbook for Street Maintenance and Construction Operations with such revisions, amendments, and supplements as are contained herein.

SC-4. CONTRACT DRAWINGS

The Contract Drawings or "Plans" on which the proposals and contracts are to be based, and which are to be supplemented by additional shop and dimension drawings of material and equipment and other drawings, where specified, are shown in the "Index of Sheets" on the cover sheet of the Plans.

SC-5. MEASUREMENT AND PAYMENT

a. Method of Measurement

The completed work shall be measured by the units described in the Proposal under each bid item that is satisfactorily completed by the Contractor. At monthly intervals, beginning one month after the Notice to Proceed, the Contractor shall submit to the City Engineer an accurate record of the work completed.

b. Basis of Payment

The amount of completed work, measured as set forth above, shall be paid for at the contract unit price bid per item described in the Proposal and shall be full compensation for furnishing supervision, testing, labor, materials and equipment required in furnishing, installing, replacing, and rehabilitating main sewer and any service laterals, complete as well as payment for temporary facilities; including temporary fencing; all erosion control materials and installation; all clearing and grubbing; reshaping the invert if necessary to create a smooth flowline; connection to existing pipes; trench excavation; rock excavation; embedment; backfill, granular trench backfill; disposal of excavated material not used as backfill; dewatering as required; bypass pumping; compaction; granular backfill material or concrete required by trench widths exceeding the maximum allowable trench width for any pipe as shown on the plans; existing utility removal, replacement and relocation; traffic control; surface restoration; replacement of unsuitable pipe foundation material; fence repair and replacement; tree removal and preservation; sodding and seeding; and incidental related items necessary to complete the work in accordance with the Specifications. Work not measured separately for payment is subsidiary to the item to which it pertains.

Measurement and payment for each work item shall be in accordance with the following:

STORM SEWER SPOT REPAIRS:

Base Bid Spot Repair Sites: Payment for each spot repair shall include but not be limited to the installation of pipe specified, fittings, and surface repairs in accordance with the lump sum value set forth in the Contractor's proposal for each site listed. There is no differentiation between sewer pipe construction for point repairs or full pipe replacement between manholes. Where pipe is referred to, these special conditions also apply to pipe-arch, where appropriate.

The lump sum price shall include full compensation for all supervision, testing, plant, labor, materials, and equipment required in furnishing and installing the sewer pipe and fittings complete as well as payment for detailed construction staking; access way preparation and restoration; pavement saw cutting if required; concrete or asphaltic driveway restoration; concrete curb and gutters; pipe plugs and flowable fill for pipe abandonments; sidewalks and ADA ramp restoration; temporary facilities and temporary fencing; all clearing and grubbing; installation and subsequent removal of erosion control devices as required; connection of new pipe to existing manholes; fittings and connections to existing pipe; trench excavation of all materials encountered; rock excavation if required; debris pile disposal; removal of existing pipe; installation of new pipe; pipe embedment; earthen backfill; disposal of excavated material not used as backfill; dewatering as required; bypass pumping; verification of service laterals; compaction; granular backfill material or concrete required by trench widths exceeding the maximum allowable trench width for any pipe as shown on the Drawings; pipe anchors and cradles, as indicated on the Drawings; abandonment or removal of existing pipe, manholes or structures as shown on the Drawings, piping and fittings of the correct size within the maximum trench width; existing utility, including power pole, bracing, removal, replacement or relocation; traffic control; surface restoration; removal and replacement of unsuitable pipe foundation material; fence repair and replacement; tree trimming, removal and disposal, protection/saving, and replacement; landscaping; placement of fertilizer,

seeding, sodding, and mulching; resetting and re-establishing property corners, pins, bars, or markers removed; post-construction surface photographic record; and any incidentals which will be required therewith.

(Diameter) RCP Pipe and Bedding: Payment for reinforced concrete pipe shall be in accordance with the unit price set forth in the Contractor's proposal for each pipe diameter and surface condition.

Measurement for payment shall be based on horizontal length of pipe actually installed as determined from the construction survey stationing. Piping shall be measured along the center line of the sewer. There is no differentiation between sewer pipe construction for point repairs or full pipe replacement between manholes. Where pipe is referred to, these special conditions also apply to pipe-arch, where appropriate.

The unit price shall include full compensation for all supervision, testing, plant, labor, materials, and equipment required in furnishing and installing the sewer pipe complete as well as payment for detailed construction staking; access way preparation and restoration; pavement saw cutting if required; temporary facilities and temporary fencing; all clearing and grubbing; installation and subsequent removal of erosion control devices as required; connection of new pipe to existing manholes; fittings and connections to existing pipe; trench excavation of all materials encountered; rock excavation if required; debris pile disposal; removal of existing pipe; installation of new pipe; pipe embedment; earthen backfill; granular trench backfill; disposal of excavated material not used as backfill; dewatering as required; bypass pumping; verification of service laterals; compaction; granular backfill material or concrete required by trench widths exceeding the maximum allowable trench width for any pipe as shown on the Drawings; pipe anchors and cradles, as indicated on the Drawings; abandonment or removal of existing pipe, piping and fittings of the correct size within the maximum trench width; existing utility, including power pole, bracing, removal, replacement or relocation; traffic control; surface restoration; removal and replacement of unsuitable pipe foundation material; fence repair and replacement; tree trimming, removal and disposal, protection/saving, and replacement; landscaping; placement of fertilizer and sod/seed and mulch; resetting and re-establishing property corners, pins, bars, or markers removed; post-construction surface photographic record; and any incidentals which will be required therewith.

Area and Curb Inlets, Junction Boxes, and Storm Manholes: Payment for area and curb inlets, junction boxes, and storm manholes shall be in accordance with the unit price set forth in the Contractor's proposal.

Measurement and payment shall be based on each installed and approved structure. The unit price shall include full compensation for all materials, labor, equipment, and other incidentals, including curb and gutter transition and cast-in-place tops as shown on the standard details, where necessary to install pre-cast concrete area inlets, curb inlets and junction boxes of the type and size, castings, and at the locations indicated. The location and elevations of existing pipes shall

be determined prior to construction of cast in place structures where not shown on the plans. As necessary, the top elevation and depth of the cast in place structures shall be modified to match existing or proposed pipe locations and elevations. Payment for Area and Curb Inlets, Junction Boxes, and Storm Manholes shall be made at the Contract unit price per structure and payment shall be for full compensation for furnishing all labor, materials, and appurtenant work. Flowable fill backfill, where required, shall be subsidiary to this item. All associated excavation shall be unclassified as to materials which may be encountered.

Trench Backfill and Restoration (Unpaved and Paved): Payment for each spot repair shall include but not be limited to the installation of pipe, fittings, and surface repairs in accordance with the lump sum value set forth in the Contractor's proposal for each site listed. There is no differentiation between storm sewer pipe construction for point repairs or full pipe replacement between manholes. Where pipe is referred to, these special conditions also apply to pipe-arch, where appropriate.

The lump sum price shall include full compensation for all supervision, testing, plant, labor, materials, and equipment required in furnishing and installing the sewer pipe and fittings complete as well as payment for detailed construction staking; access way preparation and restoration; pavement saw cutting if required; temporary facilities and temporary fencing; all clearing and grubbing; installation and subsequent removal of erosion control devices as required; connection of new pipe to existing manholes; fittings and connections to existing pipe; trench excavation of all materials encountered; rock excavation if required; debris pile disposal; removal of existing pipe; installation of new pipe; pipe embedment; earthen backfill; disposal of excavated material not used as backfill; dewatering as required; bypass pumping; verification of service laterals; compaction; granular backfill material or concrete required by trench widths exceeding the maximum allowable trench width for any pipe as shown on the Drawings; pipe anchors and cradles, as indicated on the Drawings; abandonment or removal of existing pipe, manholes or structures as shown on the Drawings; piping and fittings of the correct size within the maximum trench width; existing utility, including power pole, bracing, removal, replacement or relocation; traffic control; surface restoration; removal and replacement of unsuitable pipe foundation material; fence repair and replacement; tree trimming, removal and disposal, protection/saving, and replacement; landscaping; placement of fertilizer and sod/seed and mulch; resetting and re-establishing property corners, pins, bars, or markers removed; post-construction surface photographic record; and any incidentals which will be required therewith.

SC-6. MOBILIZATION OF EQUIPMENT

All equipment used by the Contractor having metal tracks shall not be driven over City streets other than those streets being constructed. Such equipment must be transported from one work area to the next work area.

Observe legal load restrictions when operating equipment, hauling equipment, or hauling materials on public roads; newly constructed/reconstructed base, pavement, and structures; and any existing base, pavement or structures that will remain in place. Assume responsibility for changes in legal load restrictions that occur after the project was let. Obtain the Engineer's written approval and a special permit to exceed legal load restrictions on the City street system and on newly constructed/reconstructed portions of the project.

Protect roadways and structures within project limits from damage. Observe curing periods before operating equipment or hauling loads on newly constructed pavement, reconstructed pavement, or structures. Do not haul loads of any size on pavement base, except when operations require equipment on pavement base to place material. The Contractor shall assume all responsibility for damages to roadways and structures caused by the Contractor as a result of operating equipment or hauling loads.

SC-7. INSPECTION OF WORK

The Contractor shall not commence placing concrete or backfilling of pipe/structures until such time as the City Engineer or his authorized representative has made an inspection. Form location, grades, slopes and subgrade shall have been approved prior to placing any concrete.

SC-8. BRACING AND SHORING

It shall be the contractor's responsibility to brace and shore existing structures during construction. Any additional damage to or collapse of existing structures during the contract period shall be the sole responsibility of the Contractor.

The Contractor shall brace and shore all trenches in full accordance with Occupational Safety and Health Standards - Excavations; Final Rule 29 CFR Part 1926.

Bracing and shoring shall not be paid for directly but shall be considered subsidiary to other bid items. No additional payment shall be considered for increased quantities of earthwork, asphalt removal and replacement, or increases in other items as a result of compliance with this specification.

SC-9. TRENCH BACKFILL

Flowable fill is required for all trenches within all paved portions of the ROW including future paving, if they are known, per the Manual for Infrastructure Standards for Right of Way Restoration and City of Mission Standard Details.

SC-10. SAMPLING AND TESTING

All sampling and testing deemed necessary by the Engineer shall be performed by a Testing Laboratory selected by the City. In the event that any test indicates non-compliance with the Specifications, additional testing will be paid for by the Contractor to determine acceptability of the material or methods. City reserves the right to weigh any selected truck as determined by the Engineer. The City shall only pay weighing costs and any additional costs shall be at the Contractor's expense.

SC-11. TRAFFIC SAFETY

When working in the traveled way, the Contractor shall provide adequate and suitable barriers, signs, warning lights, flaggers, and all other equipment necessary to direct and reroute traffic and protect the public from moving or stationary vehicles, equipment, and materials, and other obstructions. Also, adequate protective warning lights and signs shall be provided to warn

of any obstruction or excavation in the street, and easement area. All barricades, signs, lights and other protective devices in public right-of-way and easements shall be installed and maintained in conformity with applicable statutory requirements, the latest edition of the "Manual on Uniform Traffic Control Devices", and the "Mission Traffic Control Handbook for Street Maintenance and Construction Operations".

The Police Department, Fire Department, and Med-Act shall be notified prior to closing a street with the approval of the City Engineer.

SC-12. NOTIFICATION OF PROPERTY OWNERS

The Contractor shall provide advance notification to the adjacent property owners on all phases of the operations.

SC-13. TREE AND PLANT PROTECTION

All trees and other vegetation which must be removed to perform the work shall be removed and disposed of by the Contractor; however, no trees or cultured plants shall be unnecessarily removed unless their removal is indicated on the drawings. All trees and plants not removed shall be protected against injury from construction operations.

The Contractor shall take extra measures to protect trees designated to be preserved, such as erecting barricades or fences around the drip line, and trimming low hanging branches to prevent damage from construction equipment. Barricade or fence shall not be removed without consent of the Engineer. When installing a pipe, or any other work that may damage the tree, hand excavating or tunneling methods shall be used. Where encroachment by vehicles or equipment is expected within the drip line of the tree, the contractor will be required to place at least a 6-inch layer of organic mulch on top of the affected area to offset possible compaction. Such trees shall not be endangered by stockpiling excavated material or storing equipment within the drip line of the tree. No backfill material exceeding 4-inches in depth shall be placed within the drip line area of any tree designated to be preserved without prior consent from the Engineer.

When excavation is required within the drip line of any protected tree, the contractor shall take extra measures to protect as many roots as possible. All roots to be cut or removed shall be "cut" with a chain saw, trencher, or other methods as approved by the engineer that will leave a smooth cut surface. All roots exposed during excavation shall be protected to prevent the roots from drying out by covering the exposed area with canvas or burlap, peat moss, or mulch, and kept damp until the area has been backfilled. Where shown on the plans, trees requiring root removal of one third or more of the circumference of the root system, may require the pruning of limbs on the opposite side of the root removal or thinning the entire tree equally as directed by the Engineer. All pruning, repair, and replacement of trees and plants shall be performed by qualified nurserymen or arborists. Trees requiring trimming are as noted on the plans. This work shall not be paid for directly but shall be considered subsidiary to other bid items.

When the injury or removal of trees designated to be preserved cannot be avoided; each tree injured beyond repair or removed shall be replaced with a similar tree, or provide compensation to the City as determined by the Engineer.

SC-14. WEEDS

The Contractor shall restrict the excessive growth of weeds, grasses, and other uncultivated vegetation within the project limits in accordance with the City of Mission Municipal

Code. The Contractor shall cut down any excessive growth by mowing or trimming or as directed by the engineer.

No direct payment will be made for this work as it shall be considered subsidiary to other bid items in the contract.

SC-15. RESTORATION

a. Pre-Restoration Meeting

The Contractor shall be responsible for scheduling a pre-restoration meeting within 1 (one) week prior to beginning final grading, select soil placement, and restoration of the sodded areas in the project. The time and location of the meeting shall be approved by the Project Engineer, with required attendance by the Contractor's superintendent and any/all subcontractors involved in the restoration. The purpose of this meeting is to discuss in detail the requirements of sod restoration in the Specifications. At this meeting the Contractor shall provide:

- 1) A complete schedule of operations and proposed methods for soil preparation, sod placement, and watering.
- 2) A list of the equipment to be used for soil preparation and compaction, fertilizer distribution, sod delivery, placement and rolling, and watering.
- 3) The proposed source or sources of the sod, select soil, and water.
- 4) A list or set of "marked up" plans indicating the proposed location of each type of sod.
- 5) A list of at least 3 locations that the sod crew to be used on this project has placed sod within the previous 2 weeks.

SC-16. UTILITY MEETINGS AND UTILITY ADJUSTMENT

It shall be the duty of the Contractor to notify the serving utility companies of pending construction operations and the schedule of same, prior to any work being done on this project. The Engineer will furnish plans to the utility companies for their records. These companies will relocate and adjust their own facilities at no cost to the Contractor, except for sanitary and storm sewers. The Contractor shall be responsible for the adjustment and protection of all sanitary and storm sewer facilities. Some minor grading and backfill work may be required of the Contractor at locations of utility adjustments. This work shall be considered subsidiary to other items of work.

The Contractor shall be responsible for holding periodic utility meetings with the City, the Engineer, and utility companies during the relocation of utility lines. The frequency of meetings will initially be bi-weekly (or more frequently if necessary) and then, as relocation work begins to diminish, will be held more infrequently. The Contractor shall keep minutes of the meetings and send copies to all those in attendance.

SC-17. WATER POLLUTION CONTROL

Contractor shall prevent the pollution of streams, lakes, wetlands, drainageways or storm sewers from fuel, oils, hazardous chemicals, sediment, trash, debris, or other substances resulting from construction activities.

All trash shall be placed in dumpsters or trash barrels provided by the Contractor and accumulated trash shall be hauled offsite and properly disposed. Floating debris found in any waterbody on or immediately adjacent to construction shall be removed immediately, regardless

of source. Hazardous wastes shall be stored, transported offsite, and disposed of properly. Sanitary facilities must be made available and their use enforced by the Contractor.

All equipment used onsite shall be free of leaks and receive regular preventative maintenance and be inspected daily to reduce chance of leakage. No fueling, servicing, maintenance, or repair of equipment shall be done within 50 feet of a stream, drainageway, lake, storm sewer manhole or other water body. Fuel tanks onsite shall in good condition, free of leaks or drips, painted brightly for visibility, monitored daily and shall sit behind or within a secondary containment tank or earthen berm.

Concrete wash or rinsewater from concrete mixing equipment, tools and/or ready-mix trucks, tools, etc, may not be discharged into or be allowed to run directly into any existing water body or storm inlet. One or more locations for concrete wash out will be designated on site, such that discharges during concrete washout will be contained in a small area where waste concrete can solidify in place and excess water evaporated or infiltrated into the ground.

Chemicals or materials capable of causing pollution may only be stored onsite in their original container. Materials stored outside must be in closed and sealed water-proof containers and located outside of drainageways or areas subject to flooding. Manufacturers data regarding proper use and storage, potential impacts to the environment if released, spill response, and reportable quantities for spill reporting shall be maintained by the field superintendent onsite at all times. Locks and other means to prevent and reduce vandalism shall be used.

All spills in excess of reportable quantities shall be reported to all of the following within 24 hours of their occurrence: KDHE 24-hour spill response center (785) 296-1679; KDHE Northeast District, Lawrence, (785) 842-4600; and the National Spill Response Center 1-800-424-8802. Spills that pose immediate threat to public safety or contamination of a water body shall be reported immediately to the Fire Department at 911. Such spills shall also be reported to the Kansas Division of Emergency Management, (800) 275-0297 or (785) 296-8013.

Contractor shall respond immediately by containing with an appropriate device or earthen berms and shall prevent its migration with sawdust, sand, kitty litter, rags or other absorbents. Manufacturer recommendations shall be followed. Leaks from broken hoses will be immediately contained with hose clamps, plugs, or drained into leak-tight containers. Contractor shall have onsite at all times and ready for immediate use the necessary tools, equipment, and supplies to respond to a spill or leak. Contractor personnel shall be trained to properly respond immediately to a leak or spill. All spills shall be cleaned up and disposed of in accordance with applicable regulations or as directed by Kansas Division of Health and Environment or other applicable agency.

Herbicides, pesticides and fertilizers used as part of the work shall be applied only in accordance with manufacturer recommendations. Direct spray into water bodies shall be avoided. Such chemicals shall not be used if rain is forecast within 24 hours, unless they are approved for wet weather application.

Care will be taken to avoid excessive disturbance or erosion of land area and controls shall be maintained to prevent migration of silt and sediments into water bodies. Provisions of the contract for erosion and sediment control shall be followed.

SC-18. RIGHT-OF-WAY

Right-of-way and easements are currently available for this project.

The Contractor shall confine his construction operations to the right-of-way limits and easements provided for the project. Equipment or materials shall not be stored beyond these limits without the express approval of the owner of such property. The Engineer shall be informed as to any arrangements that Contractor makes on his behalf in these matters.

SC-19. CONSTRUCTION TIMELINE AND LIMITATIONS

The following limitations shall apply:

- A. The Notice to Proceed is anticipated to be no sooner than July 6, 2017.**
- B. The undersigned further agrees to complete all work by September 15, 2017.**

SECTION 02630 - STORM DRAINAGE

PART 1 - GENERAL

1.1 SUMMARY

- A. Section Includes:
 - 1. Pipe and fittings.
 - 2. Nonpressure transition couplings.

1.2 ACTION SUBMITTALS

- A. Product Data: For each type of product indicated.
- B. Shop Drawings:
 - 1. Product Certificates: For each type of pipe and fitting, from manufacturer.

1.3 INFORMATIONAL SUBMITTALS

- A. N/A

1.4 PROJECT CONDITIONS

- A. Interruption of Existing Storm Drainage Service: Do not interrupt service to facilities occupied by Owner or others unless permitted under the following conditions and then only after arranging to provide temporary service according to requirements indicated:
 - 1. Notify Owner no fewer than two days in advance of proposed interruption of service.
 - 2. Do not proceed with interruption of service without Owner's written permission.

PART 2 - PRODUCTS

- A. Material: Reinforced Concrete Culvert Pipe.
- B. Form: [**precast reinforced concrete**].
 - 1. **Minimum Thickness:** 2.5 inches.
- C. Supports, Anchors, and Setting Devices: Manufacturer's standard unless otherwise indicated.
- D. Channel-Section Joining and Fastening Materials: As recommended by system manufacturer.

PART 3 - EXECUTION

3.1 EARTHWORK

A. Excavation, trenching, and backfilling are as summarized below:

1. Depth of cover. The minimum depth of cover for reinforced concrete pipes shall be 18 inches.
2. Trench construction. The minimum width of the trench shall be wide enough to permit the pipe to be easily placed and joined and to allow the initial backfill material to be uniformly placed and compacted under the haunches and along the side of the pipe.
3. The trench bottom shall be uniform so that the pipe lies on the bottom without bridging. Clods, rocks, and uneven spots that can damage the pipe or cause non-uniform support shall be removed.
4. If rocks, boulders, or any other materials that can damage the pipe are encountered, the trench bottom shall be undercut a minimum of 4 inches below final grade and filled with bedding material consisting of sand or compacted fine-grained soils no greater than ½ inch in diameter.
5. Provisions shall be made to insure safe working conditions where unstable soil, trench depth, or other conditions can be hazardous to personnel working in the trench.
6. Laying and bedding the pipe. Unless otherwise specified, the pipe shall be installed in accordance with the manufacturer's recommendations. Pipe shall be installed so no reversal of grade between joints results unless otherwise shown on the drawings. The pipe shall be installed with the outside laps of circumferential joints pointing upstream and with longitudinal laps at the sides near the vertical mid-height of the pipe.
7. The pipe shall be firmly and uniformly bedded throughout its full length to the depth and in the manner specified on the drawings.
8. Backfill material shall be soil or sand that is free from rocks or stones larger than 1 inch in diameter.
9. At the time of placement, the moisture content of the material shall be such that the required degree of compaction can be obtained with the backfill method to be used. The initial backfill material shall be placed so that the pipe will not be displaced, excessively deformed, or damaged.
10. If backfilling is done by hand or mechanical means, the initial fill shall be compacted firmly around and above the pipe as required to provide adequate lateral support to the pipe.

11. The pipe shall be loaded sufficiently during backfilling to prevent displacement from line and grade and to maintain full contact with the bedding during the placement operations.

3.2 PIPE STORAGE AND HANDLING

- A. Pipe shall be braced as required to maintain its roundness when stored and handled.
- B. Pipe shall be stored on padded skids, tires, or other suitable means so that pipe will not be damaged. Pipe shall also be piled and blocked with strips between tiers.
- C. Pipe shall be handled with wide belt slings, padded forks, or other means that will not damage the pipe. Chains, cables, or other equipment likely to cause damage to the pipe shall not be used.
- D. Pipe shall not be rolled or dragged on the ground.
- E. Each section of pipe shall be delivered in the field as near as practicable to the place where it is to be installed.
- F. If the pipe is supported, as for welding, supports shall be of sufficient width and number and be padded, if necessary.

3.3 PIPING INSTALLATION

- A. General Locations and Arrangements: Drawing plans and details indicate general location and arrangement of underground storm drainage piping. Location and arrangement of piping layout take into account design considerations. Install piping as indicated, to extent practical. Where specific installation is not indicated, follow piping manufacturer's written instructions.
- B. Install piping beginning at low point, true to grades and alignment indicated with unbroken continuity of invert. Install gaskets, seals, sleeves, and couplings according to manufacturer's written instructions for use of lubricants, cements, and other installation requirements.
- C. Install proper size increasers, reducers, and couplings where different sizes or materials of pipes and fittings are connected. Reducing size of piping in direction of flow is prohibited.
- D. Install gravity-flow, nonpressure drainage piping according to the following:
 1. Install piping pitched down in direction of flow.
 2. Install reinforced concrete stormsewer piping according to ASTM C76-16.

3.4 PIPE JOINT CONSTRUCTION

- A. Pipe joints shall meet ASTM C443 for precast reinforced concrete pipe using rubber gaskets.

3.5 IDENTIFICATION

- A. Materials and their installation are specified in the section on "Earthwork." Arrange for installation of green warning tape directly over piping and at outside edge of underground structures.
 - 1. Use[**warning tape or**] detectable warning tape over any existing ferrous piping.
 - 2. Use detectable warning tape over nonferrous piping and over edges of underground structures.

3.6 FIELD QUALITY CONTROL

- A. Pipe shall be visually inspected for damage. Inspect interior of piping to determine whether line displacement or other damage has occurred. Inspect after approximately 24-inches of backfill is in place, and again at completion of Project.
 - 1. Submit separate reports for each system inspection.
 - 2. Defects requiring correction include the following:
 - a. Alignment: Less than full diameter of inside of pipe is visible between structures.
 - b. Deflection: Flexible piping with deflection that prevents passage of ball or cylinder of size not less than 92.5 percent of piping diameter.
 - c. Damage: Crushed, broken, cracked, bent, or otherwise damaged piping.
 - d. Infiltration: Water leakage into piping.
 - e. Exfiltration: Water leakage from or around piping.
 - 3. Replace defective piping using new materials, and repeat inspections until defects are within allowances specified.
 - 4. Reinspect and repeat procedure until results are satisfactory.
- B. Test new piping systems, and parts of existing systems that have been altered, extended, or repaired, for leaks and defects.
 - 1. Do not enclose, cover, or put into service before inspection and approval.
 - 2. Test completed piping systems according to requirements of authorities having jurisdiction.
 - 3. Schedule tests and inspections by authorities having jurisdiction with at least 24 hours' advance notice.
 - 4. Submit separate report for each test.
 - 5. Gravity-Flow Storm Drainage Piping: Test according to requirements of authorities having jurisdiction, UNI-B-6, and the following:
 - a. Exception: Piping with soiltight joints unless required by authorities having jurisdiction.
- C. Leaks and loss in test pressure constitute defects that must be repaired.
- D. Replace leaking piping using new materials, and repeat testing until leakage is within allowances specified.

END OF SECTION 02630

SECTION 02230 - SITE CLEARING

PART 1 - GENERAL

1.1 SUMMARY

A. Section Includes:

1. Protecting existing vegetation to remain.
2. Removing existing vegetation.
3. Clearing and grubbing.
4. Stripping and stockpiling topsoil.
5. Removing above- and below-grade site improvements.
6. Disconnecting, capping, or sealing site utilities.
7. Temporary erosion and sedimentation control.

1.2 MATERIAL OWNERSHIP

- A. Except for materials indicated to be stockpiled or otherwise remain Owner's property, cleared materials shall become Contractor's property and shall be removed from Project site.

1.3 FIELD CONDITIONS

- A. Traffic: Minimize interference with adjoining roads, streets, walks, and other adjacent occupied or used facilities during site-clearing operations.
1. Do not close or obstruct streets, walks, or other adjacent occupied or used facilities without permission from Owner and authorities having jurisdiction.
 2. Provide alternate routes around closed or obstructed trafficways if required by Owner or authorities having jurisdiction.
- B. Utility Locator Service: Notify utility locator service for area where Project is located before site clearing.
- C. Do not commence site clearing operations until temporary erosion- and sedimentation-control measures indicated on the plans are in place.
- D. Tree- and Plant-Protection Zones: Protect according to requirements in Section 02231 "Tree Protection and Trimming."

PART 2 - PRODUCTS

2.1 MATERIALS

- A. Satisfactory Soil Material: Instructions for trenching, installation and backfill is located in the "Earthwork" section of the Storm Drainage Specifications.. Obtain approved borrow soil material off-site when satisfactory soil material is not available on-site.

PART 3 - EXECUTION

3.1 PREPARATION

- A. Protect and maintain benchmarks and survey control points from disturbance during construction.
- B. Verify that trees, shrubs, and other vegetation to remain or to be relocated have been flagged and that protection zones have been identified and enclosed according to requirements in Section 02231 "Tree Protection and Trimming."
- C. Protect existing site improvements to remain from damage during construction.
 - 1. Restore damaged improvements to their original condition, as acceptable to Owner.

3.2 TEMPORARY EROSION AND SEDIMENTATION CONTROL

- A. Provide temporary erosion- and sedimentation-control measures to prevent soil erosion and discharge of soil-bearing water runoff or airborne dust to adjacent properties and walkways, according to erosion- and sedimentation-control Drawings and requirements of authorities having jurisdiction.
- B. Verify that flows of water redirected from construction areas or generated by construction activity do not enter or cross protection zones.
- C. Inspect, maintain, and repair erosion- and sedimentation-control measures during construction until permanent vegetation has been established.
- D. Remove erosion and sedimentation controls, and restore and stabilize areas disturbed during removal.

3.3 TREE AND PLANT PROTECTION

- A. Protect trees and plants remaining on-site according to requirements in Section 02231 "Tree Protection and Trimming."

- B. Repair or replace trees, shrubs, and other vegetation indicated to remain or be relocated that are damaged by construction operations according to requirements in Section 02231 "Tree Protection and Trimming."

3.4 EXISTING UTILITIES

- A. Locate, identify, disconnect, and seal or cap utilities indicated to be removed or abandoned in place.
 - 1. Arrange with utility companies to shut off indicated utilities.
- B. Interrupting Existing Utilities: Do not interrupt utilities serving facilities occupied by Owner or others, unless permitted under the following conditions and then only after arranging to provide temporary utility services according to requirements indicated:
 - 1. Notify Architect not less than two days in advance of proposed utility interruptions.
 - 2. Do not proceed with utility interruptions without Architect's written permission.
- C. Removal of underground utilities is included in earthwork sections; in applicable fire suppression, plumbing, HVAC, electrical, communications, electronic safety and security, and utilities sections; and in Section 02221 "Building Demolition" and Section 01732 "Selective Demolition."

3.5 CLEARING AND GRUBBING

- A. Remove obstructions, trees, shrubs, and other vegetation to permit installation of new construction.
 - 1. Grind down stumps and remove roots larger than 3 inches in diameter, obstructions, and debris to a depth of 18 inches below exposed subgrade.
 - 2. Use only hand methods or air spade for grubbing within protection zones.
- B. Fill depressions caused by clearing and grubbing operations with satisfactory soil material unless further excavation or earthwork is indicated.
 - 1. Place fill material in horizontal layers not exceeding a loose depth of 8 inches, and compact each layer to a density equal to adjacent original ground.

3.6 TOPSOIL STRIPPING

- A. Remove sod and grass before stripping topsoil.
- B. Strip topsoil to depth of 6 inches in a manner to prevent intermingling with underlying subsoil or other waste materials.
- C. Stockpile topsoil away from edge of excavations without intermixing with subsoil or other materials. Grade and shape stockpiles to drain surface water. Cover to prevent windblown dust and erosion by water.

3.7 SITE IMPROVEMENTS

- A. Remove existing above- and below-grade improvements as indicated and necessary to facilitate new construction.

3.8 DISPOSAL OF SURPLUS AND WASTE MATERIALS

- A. Remove surplus soil material, unsuitable topsoil, obstructions, demolished materials, and waste materials including trash and debris, and legally dispose of them off Owner's property.
- B. Separate recyclable materials produced during site clearing from other nonrecyclable materials. Store or stockpile without intermixing with other materials, and transport them to recycling facilities. Do not interfere with other Project work.

END OF SECTION 02230

SECTION 01322 - PHOTOGRAPHIC DOCUMENTATION

PART 1 - GENERAL

1.1 SUMMARY

- A. Section includes administrative and procedural requirements for the following:
 - 1. Preconstruction photographs.
 - 2. Periodic construction photographs.
- B. Related Requirements:
 - 1. Section 01770 "Closeout Procedures" for submitting photographic documentation as Project Record Documents at Project closeout.

1.2 INFORMATIONAL SUBMITTALS

- A. Key Plan: Submit key plan of Project site and building with notation of vantage points marked for location and direction of each photograph. Indicate elevation or story of construction. Include same information as corresponding photographic documentation.
- B. Digital Photographs: Submit unaltered, original, full-size image files within seven (7) days of taking photographs.
 - 1. Digital Camera: Minimum sensor resolution of eight (8) megapixels.
 - 2. Identification: Provide the following information with each image description in file metadata tag:
 - a. Name of Project.
 - b. Name and contact information for photographer.
 - c. Date photograph was taken.
 - d. Description of vantage point, indicating location, direction (by compass point), and elevation or story of construction.
- C. Construction Photographs: Submit one (1) prints of each photographic view within seven (7) days of taking photographs.
 - 1. Format: 8-by-10-inch smooth-surface matte prints on single-weight, commercial-grade photographic paper; enclosed back to back in clear plastic sleeves that are punched for standard three-ring binder.
 - 2. Identification: On back of each print, provide an applied label or rubber-stamped impression with the following information:
 - a. Name of Project.
 - b. Name of Contractor.
 - c. Date photograph was taken if not date stamped by camera.

- d. Description of vantage point, indicating location, direction (by compass point), and elevation or story of construction.
- e. Unique sequential identifier keyed to accompanying key plan.

1.3 QUALITY ASSURANCE

- A. Photographer Qualifications: An individual who has been regularly engaged as a professional photographer of construction projects for not less than three years.

1.4 USAGE RIGHTS

- A. Obtain and transfer copyright usage rights from photographer to Owner for unlimited reproduction of photographic documentation.

PART 2 - PRODUCTS

2.1 PHOTOGRAPHIC MEDIA

- A. Digital Images: Provide images in JPG format, with minimum size of eight (8) megapixels.

PART 3 - EXECUTION

3.1 CONSTRUCTION PHOTOGRAPHS

- A. Photographer: Engage a qualified photographer to take construction photographs.
- B. General: Take photographs using the maximum range of depth of field, and that are in focus, to clearly show the Work. Photographs with blurry or out-of-focus areas will not be accepted.
 - 1. Maintain key plan with each set of construction photographs that identifies each photographic location.
- C. Digital Images: Submit digital images exactly as originally recorded in the digital camera, without alteration, manipulation, editing, or modifications using image-editing software.
 - 1. Date and Time: Include date and time in file name for each image.
 - 2. Field Office Images: Maintain one set of images accessible in the field office at Project site, available at all times for reference. Identify images in the same manner as those submitted to Owner or Owner Representative.
- D. Preconstruction Photographs: Before commencement of excavation, take photographs of Project site and surrounding properties, including existing items to remain during

construction, from different vantage points, as directed by the Owner or Owner Representative.

1. Flag construction limits before taking construction photographs.
 2. Take ten (10) photographs to show existing conditions adjacent to property before starting the Work.
 3. Take ten (10) photographs of existing buildings either on or adjoining property to accurately record physical conditions at start of construction.
- E. Periodic Construction Photographs: Take ten (10) photographs weekly and select vantage points to show status of construction and progress since last photographs were taken.
- F. Final Completion Construction Photographs: Take ten (10) color photographs after date of Substantial Completion for submission as Project Record Documents. Owner or Owner Representative will inform photographer of desired vantage points.
- G. Additional Photographs: Owner or Owner Representative may request photographs in addition to periodic photographs specified. Additional photographs will be paid for by Change Order and are not included in the Contract Sum.
1. Three days' notice will be given, where feasible.
 2. In emergency situations, take additional photographs within 24 hours of request.
 3. Circumstances that could require additional photographs include, but are not limited to, the following:
 - a. Special events planned at Project site.
 - b. Immediate follow-up when on-site events result in construction damage or losses.
 - c. Photographs to be taken at fabrication locations away from Project site. These photographs are not subject to unit prices or unit-cost allowances.
 - d. Substantial Completion of a major phase or component of the Work.
 - e. Extra record photographs at time of final acceptance.
 - f. Owner's request for special publicity photographs.

END OF SECTION 01322

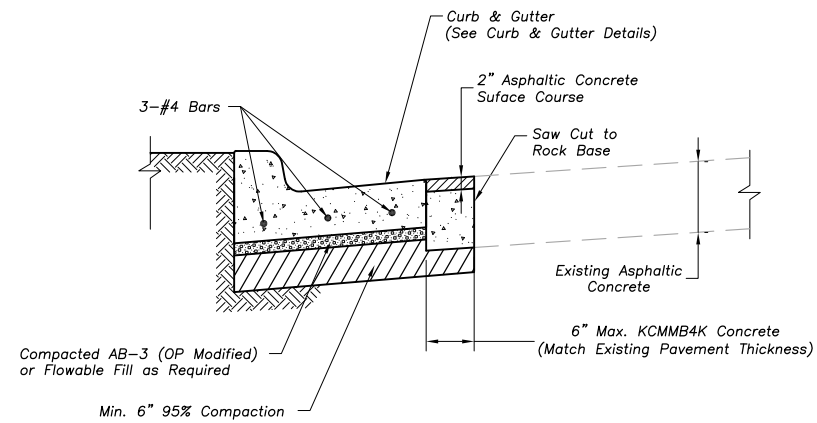

Curb Replacement Notes:

1. Overland Park Municipal Code (OPMC) and Overland Park Design and Construction Standards Manual (OPDCSM) are incorporated, except as otherwise noted.
2. 1/2" premolded expansion joints shall be placed at points of curvature, curb returns, curb inlets, and at 250' centers. The expansion joints, except @ curb returns and curb inlets, shall be sealed in accordance with OPDCSM. Contraction joints shall be 2" deep, and placed at 15' intervals equally spaced between expansion joints.
3. Concrete used in this work shall be KCMMB4K and shall meet the requirements of the OPMC.

CURB REPLACEMENT DETAIL

Not to Scale

Year 2016 Edition

REVISIONS:		 <p>ABOVE AND BEYOND. BY DESIGN.</p>
05/20/03	Notes:	
07/01/03	Concrete Mix Designation;	
Jan. 2006	Miscellaneous;	
Feb. 2008	OPMC Reference	DEPARTMENT OF PUBLIC WORKS STANDARD DETAILS
RELATED ORDINANCES:		CURB REPLACEMENT DETAIL
	OPMC Title 13	

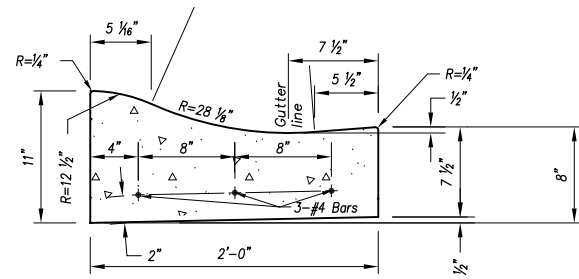

Standard Type "A" Curb

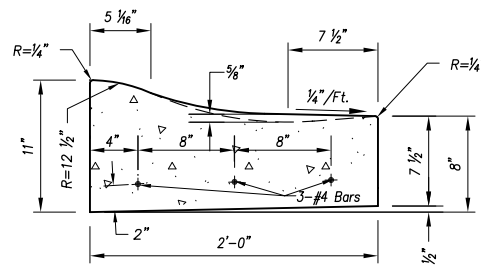

Type "A - Dry" Curb

NOTE: in transitions, water shall flow from the gutter of Type "A" curb to the lip of Type "A-Dry" curb at 0.5% min. slope.

Curb & Gutter Notes:

- The Overland Park Municipal Code (OPMC) and Overland Park Design and Construction Standards Manual (OPDCSM) are incorporated, except as otherwise noted.
- 1/2" preformed expansion joints shall be placed at points of curvature, curb returns, curb inlets, and at 250' centers. The expansion joints shall be sealed in accordance with OPDCSM. Contraction joints shall be 2" deep, and placed at 15' intervals equally spaced between expansion joints.
- All concrete used in this work shall meet the requirements of the OPMC. KCMMB4K Concrete shall be used throughout.
- For hand-formed curb all reinforcing steel shall be supported on fabricated steel bar supports @ 3'-0" maximum spacing, or as directed by the City Engineer.
- See sidewalk ramp details for typical sidewalk ramp curb & gutter sections.

CONCRETE CURB & GUTTER

Not to Scale

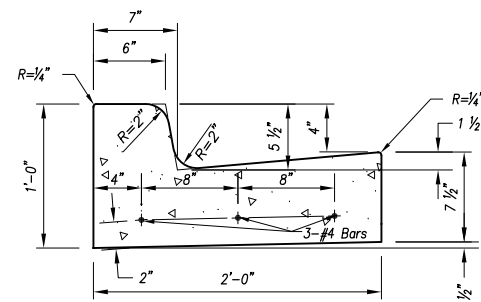

Standard Type "B" Curb

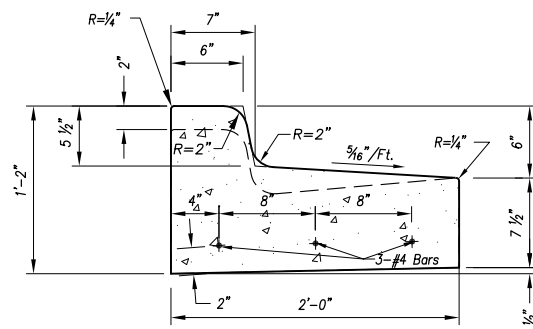

Type "B - Dry" Curb

NOTE: in transitions, water shall flow from the gutter of Type "B" curb to the lip of Type "B-Dry" curb at 0.5% min. slope.

Curb & Gutter Notes:

- The Overland Park Municipal Code (OPMC) and Overland Park Design and Construction Standards Manual (OPDCSM) are incorporated, except as otherwise noted.
- 1/2" preformed expansion joints shall be placed at points of curvature, curb returns, curb inlets, and at 250' centers. The expansion joints shall be sealed in accordance with OPDCSM. Contraction joints shall be 2" deep, and placed at 15' intervals equally spaced between expansion joints.
- All concrete used in this work shall meet the requirements of the OPMC. KCMMB4K Concrete shall be used throughout.
- For hand-formed curb all reinforcing steel shall be supported on fabricated steel bar supports @ 3'-0" maximum spacing, or as directed by the City Engineer.
- See sidewalk ramp details for typical sidewalk ramp curb & gutter sections.

CONCRETE CURB & GUTTER

Not to Scale

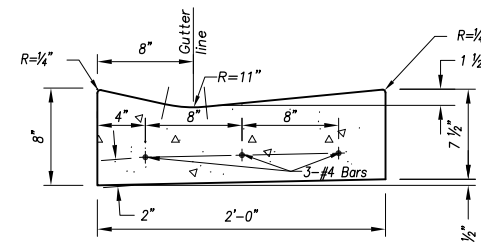

Standard Type "C" Curb*

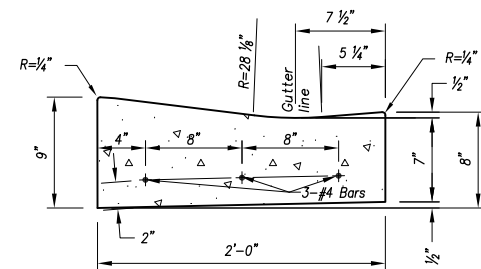

Type "C-1" Curb *
(Use w/ type "A" curb)

* Use for commercial entrances

Curb & Gutter Notes:

- The Overland Park Municipal Code (OPMC) and Overland Park Design and Construction Standards Manual (OPDCSM) are incorporated, except as otherwise noted.
- 1/2" preformed expansion joints shall be placed at points of curvature, curb returns, curb inlets, and at 250' centers. The expansion joints shall be sealed in accordance with OPDCSM. Contraction joints shall be 2" deep, and placed at 15' intervals equally spaced between expansion joints.
- All concrete used in this work shall meet the requirements of the OPMC. KCMMB4K Concrete shall be used throughout.
- For hand-formed curb all reinforcing steel shall be supported on fabricated steel bar supports @ 3'-0" maximum spacing, or as directed by the City Engineer.
- See sidewalk ramp details for typical sidewalk ramp curb & gutter sections.

CONCRETE CURB & GUTTER

Not to Scale

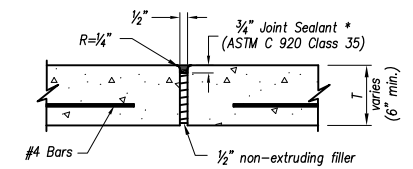

* - Joint Sealant shall be installed within 48 Hours of curb placement

Expansion Joint

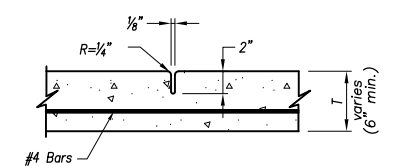

Contraction Joint

JOINT DETAILS

Not to Scale

Year 2016 Edition

REVISIONS:	
07/01/03	Concrete Mix Designation,
Jan. 2008	Notes
Feb. 2008	OPMC Reference
RELATED ORDINANCES:	
OPMC Title 13	



DEPARTMENT OF PUBLIC WORKS
STANDARD DETAILS

CONCRETE CURB WITH ASPHALT PAVEMENT
(COLLECTOR AND RESIDENTIAL STREETS)

DATE: 09/28/99

SHEET: 10

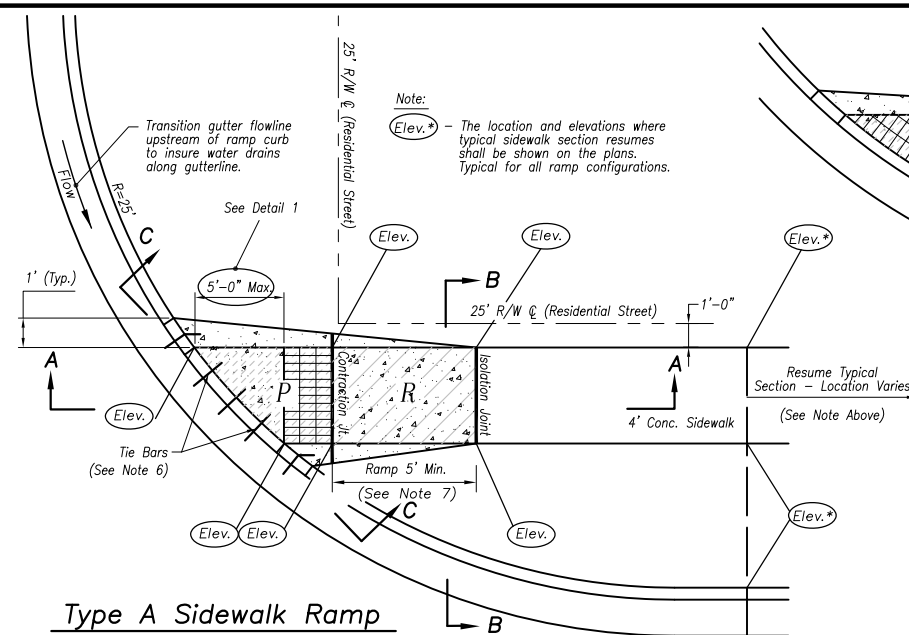

Detail 1
Detectable Warning placement when setback criteria is exceeded

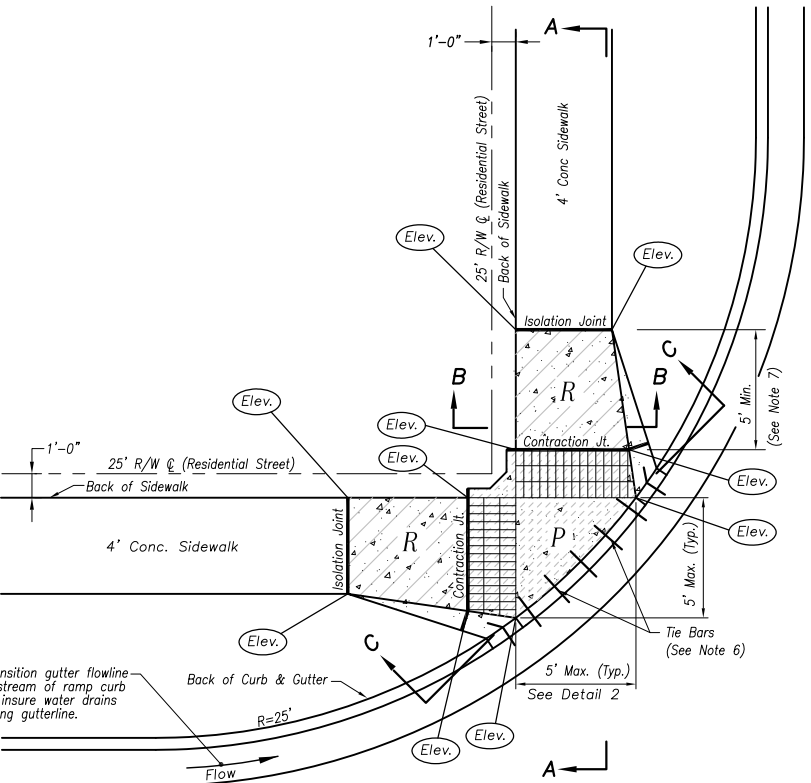
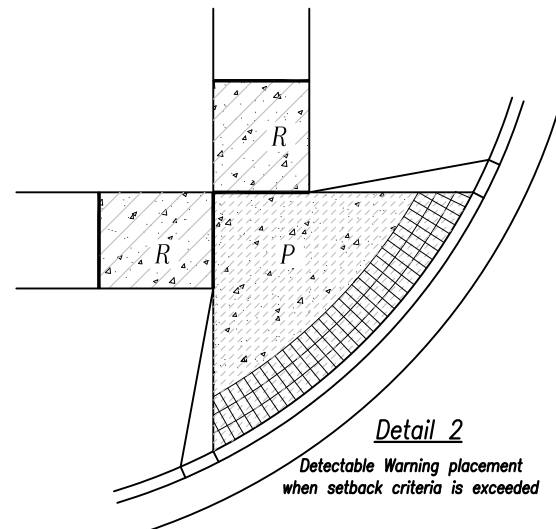

Type B Sidewalk Ramp

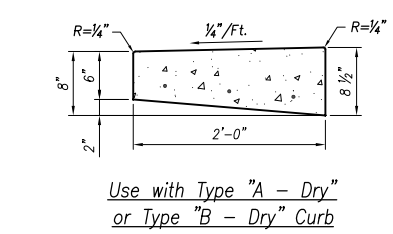
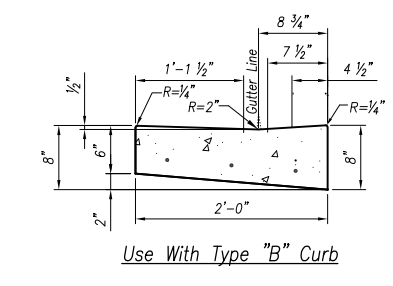
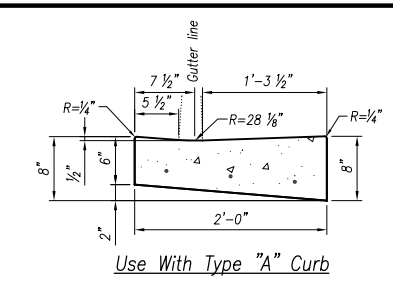
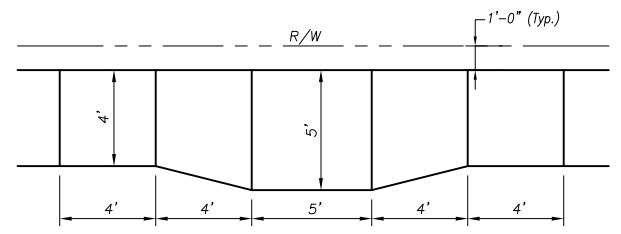

Street Curb Detail at Ramp
Note: See Standard Curb Detail for additional requirements

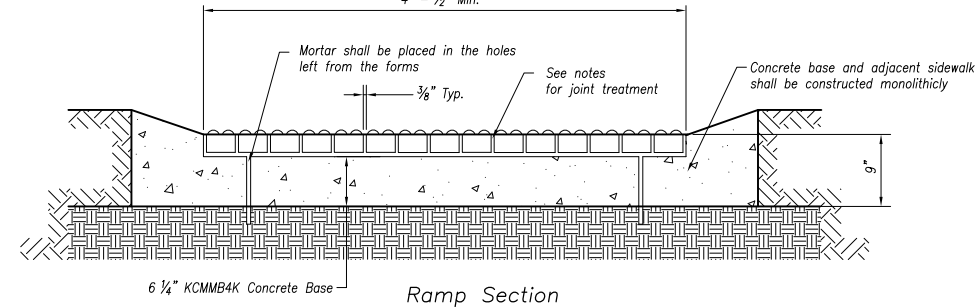
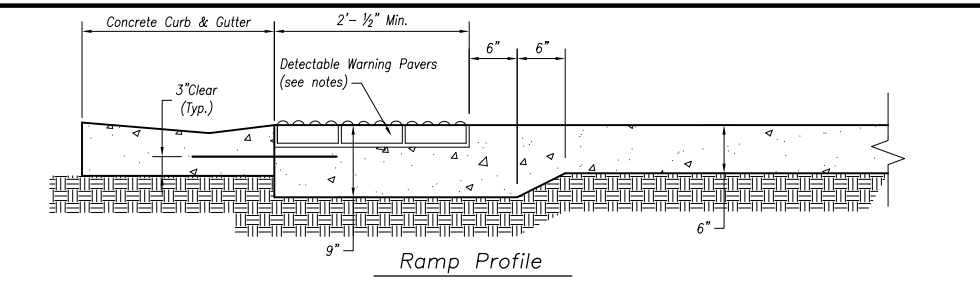

Sidewalk & Sidewalk Ramp Notes:

- Overland Park Municipal Code (OPMC) and Overland Park Design and Construction Standards Manual (OPDCSM) are incorporated, except as otherwise noted. KCMMB4K Concrete shall be used throughout.
- Sidewalk ramp location determined from the intersection of the extension of back of sidewalk and back of curb & gutter.
- ADA compliance will be measured at points labeled (Elev.). Slope between these points shall be calculated and shown on the plans. Chord distance from PC & PT to fully depressed curb section of curb return shall be shown on the plans.
- Longitudinal joint spacing and Landing length to match width of sidewalk (4' Min.).
- Isolation joints shall be placed where walk abuts driveways and similar structures, and 250' centers max.
- Install 18" tie bars #4 epoxy coated @ 18" o.c. and through wings as shown.
- Sidewalk Ramp shall be lengthened to provide ADA compliant slope but need not exceed 15' regardless of resulting slope.
- ADA maximum ramp slope = 1"/ft. ADA maximum cross slope = 2%.
- Curb depression at ramp opening shall be staked prior to curb construction.
- See Curb Replacement Details for additional requirements.
- No casting or utility boxes shall be allowed in ramps, landings or pans.
- Do not scale these drawings for dimensions.

Paver Brick Notes:

- Paving Brick shall be 2 1/4" x 3 5/8" x 7 5/8" and shall meet the requirements of ASTM C902 for Class SX Type 1 Brick and ASTM C1272. See Approved Materials List for pre-approved brick and alternative products.
- The bricks shall be placed in a Soldier Course pattern on Type A ramps or in Herringbone or Soldier Course pattern on Type B ramps as shown.
- The bricks shall be saw cut only and any brick shall not be less than 25% of a full brick. Any partial truncated dome shall be removed.
- Type M mortar shall be used for the setting bed and grouted joints in accordance with ASTM C270, Table 1 (Masonry Cement Type only).
- Detectable warning surface to extend a minimum of 2 ft. in direction of travel.

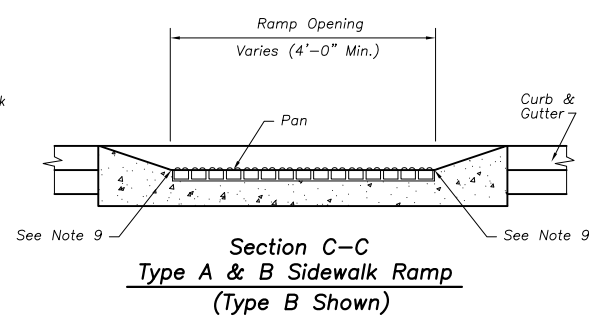
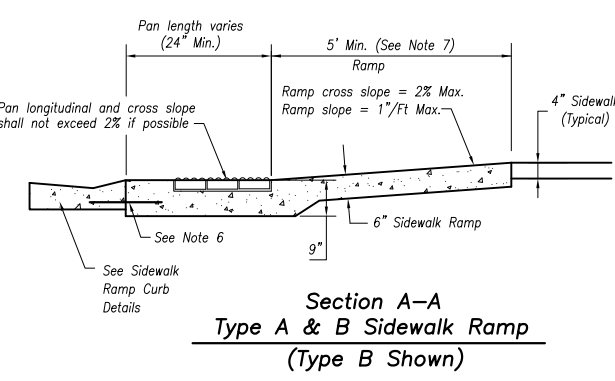
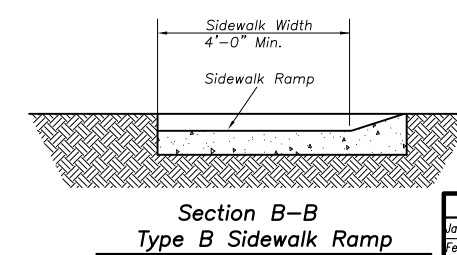
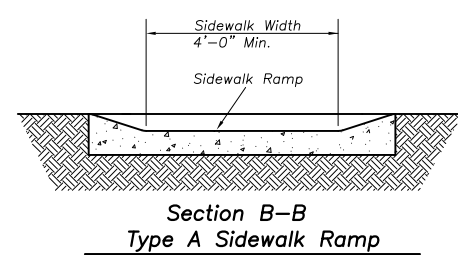
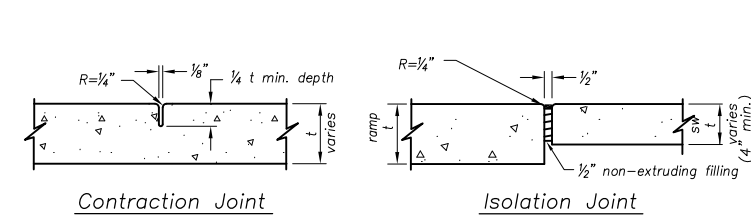
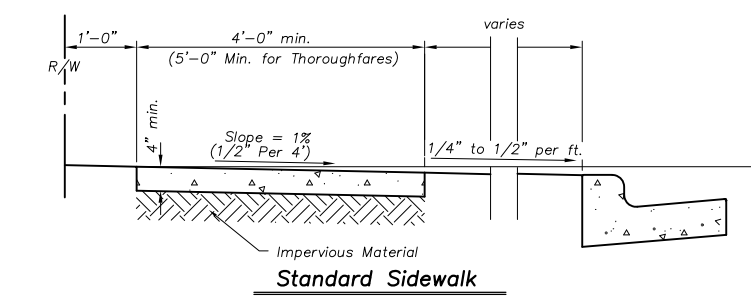

REVISIONS:	
Jan. 2004	ADA Compliance
Feb. 2005	Miscellaneous
Jan. 2006	ADA Compliance
Dec. 2006	ADA Compliance
RELATED ORDINANCES:	
OPMC Title 13	

Year 2016 Edition

OVERLAND PARK
KANSAS
ABOVE AND BEYOND. BY DESIGN.

DEPARTMENT OF PUBLIC WORKS
STANDARD DETAILS

SIDEWALK & SIDEWALK RAMP DETAILS

DATE: 01/20/04 SHEET: 32_a

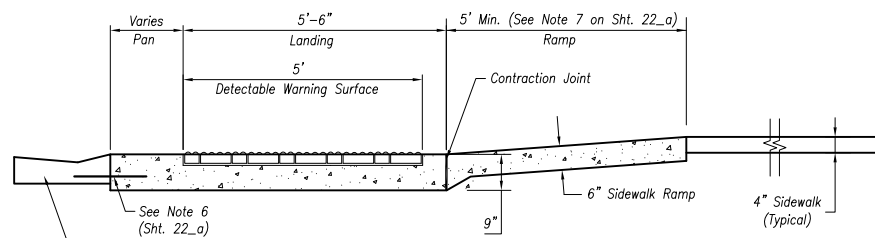

Section A-A
Type B Sidewalk Ramp
(Thoroughfare/Thoroughfare Configuration)

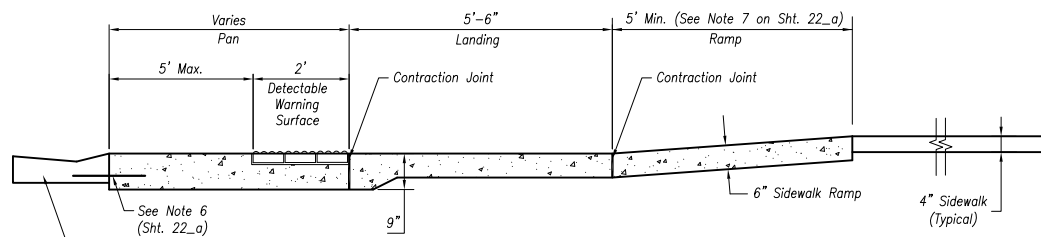

Section A-A
Type B Sidewalk Ramp
(Thoroughfare/Collector Configuration)

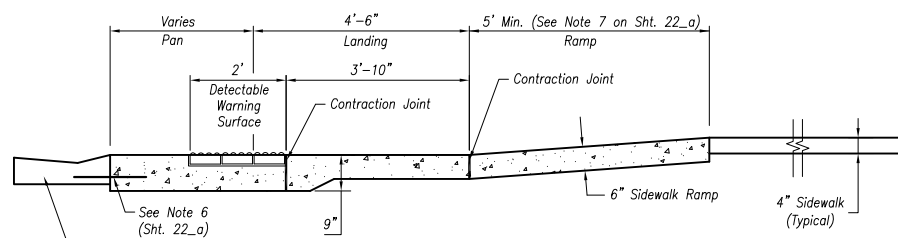

Section A-A
Type B Sidewalk Ramp
(Thoroughfare/Residential Configuration)

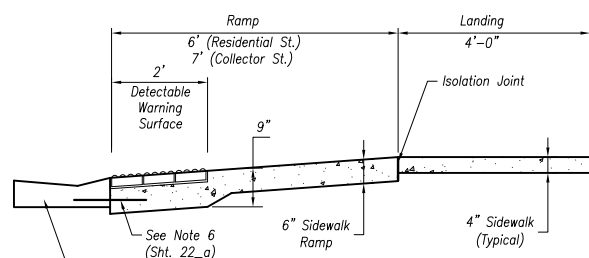

Section A-A
Type B Sidewalk Ramp
(Mid-Block Ramp Detail)

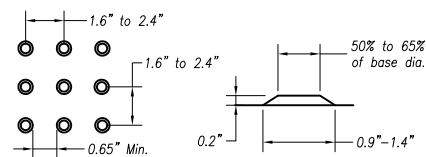

Truncated Dome Dimensions

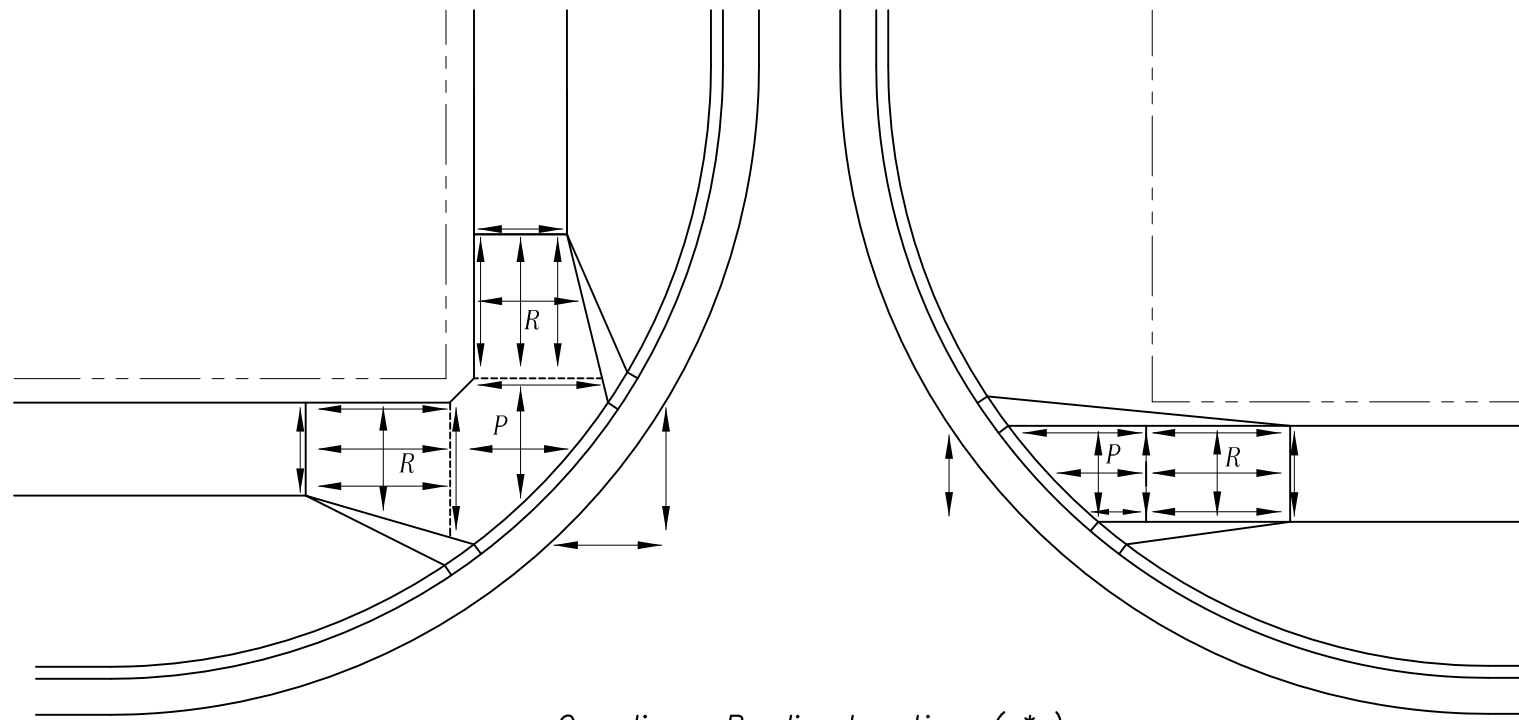

Compliance Reading Locations (*)

* - Measurements shall be taken in accordance with current PROWAG requirements.

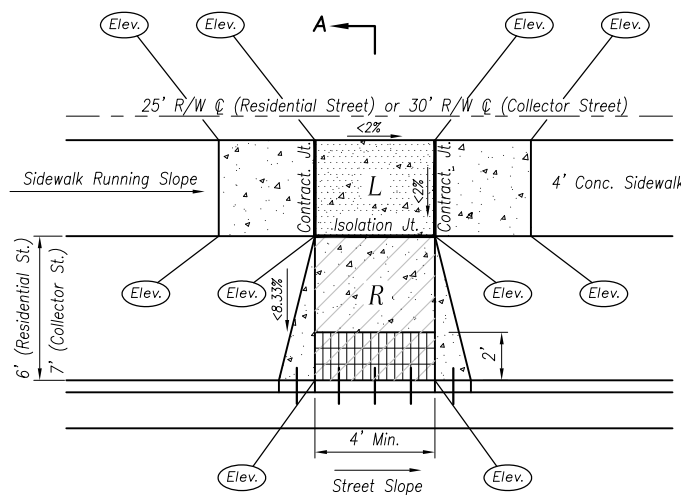

Notes:

- Ramp cross slope will transition from street slope to 2% or less at landing.
- Landing elevation will be set to limit maximum ramp slope 1"/ft.
- If sidewalk running slope is 6% or less, use 1 square on either side of landing to transition from running slope to landing slope.

Legend:

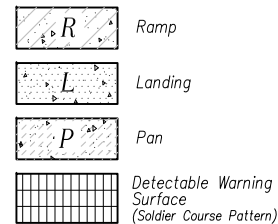

Sidewalk Ramp Elements General Requirements.

RAMP (Required to transition elevation):
 Max Longitudinal Slope - 8.33%
 Max Cross Slope - 2%
 Min Width - 4'
 Min Length - 5'

LANDING (Required to change direction of travel):
 Max Longitudinal Slope - 2%
 Max Cross Slope - 2%
 Min Width - 4'

PAN: Max Longitudinal Slope - 2% (where possible)
 Max Cross Slope - 2% (where possible)

DETECTABLE WARNING SURFACE: Width equals Ramp Opening Width @ Curb
 Min Length - 2'
 Domes should be aligned with direction of travel.

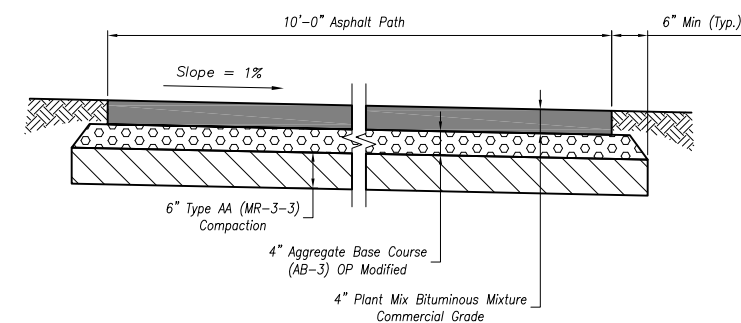

Standard Asphalt Bike/Hike Path

Year 2016 Edition

REVISIONS:	
Jan. 2004	ADA Compliance
Feb. 2005	Miscellaneous
Jan. 2006	ADA Compliance

RELATED ORDINANCES:	
OPMC Title 13	

OVERLAND PARK
KANSAS
ABOVE AND BEYOND. BY DESIGN.

DEPARTMENT OF PUBLIC WORKS
STANDARD DETAILS

SIDEWALK & SIDEWALK RAMP DETAILS

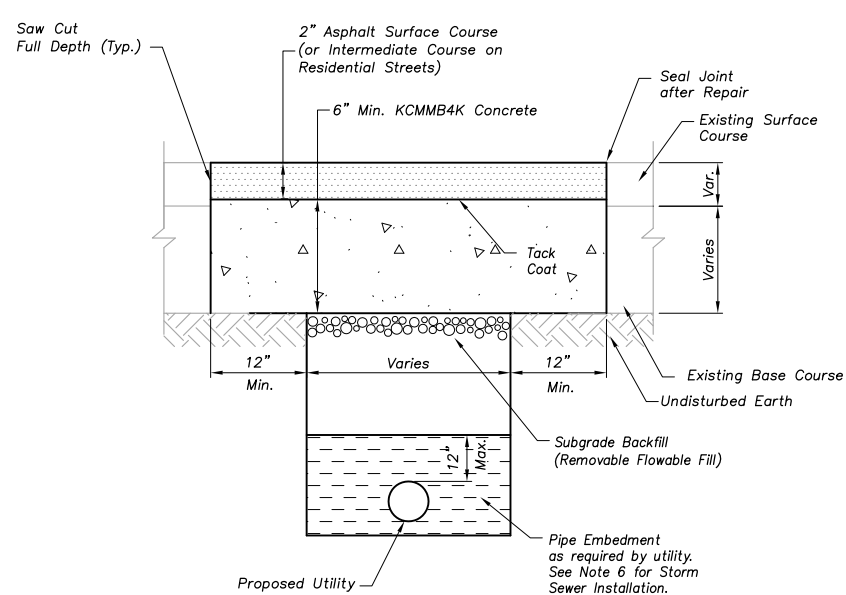

**Asphaltic Concrete Street Repair
Type I
(Concrete Base /w Asphaltic Concrete Surface)**

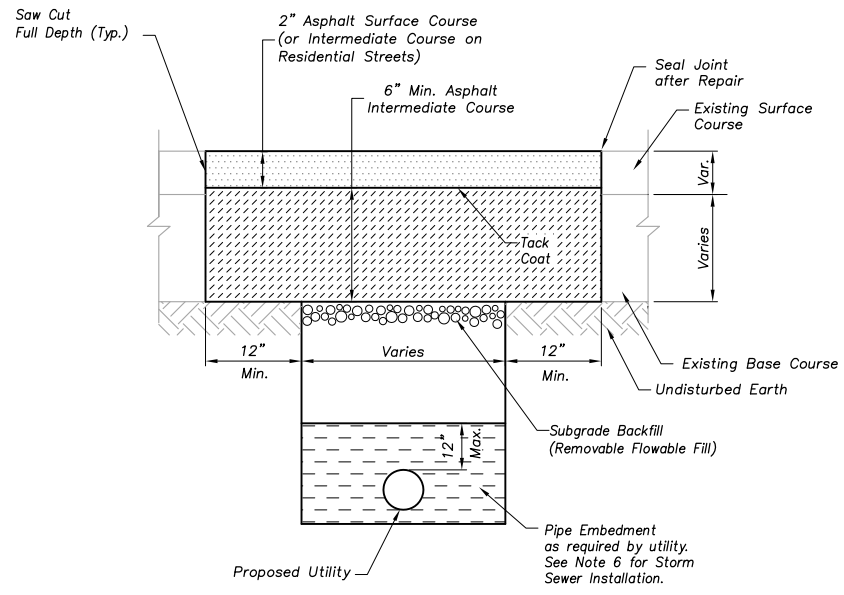

**Asphaltic Concrete Street Repair
Type II *
(Full Depth Asphaltic Concrete)**

* - Type II Street Repair May be Used Only if Excavation Width Exceeds 6'

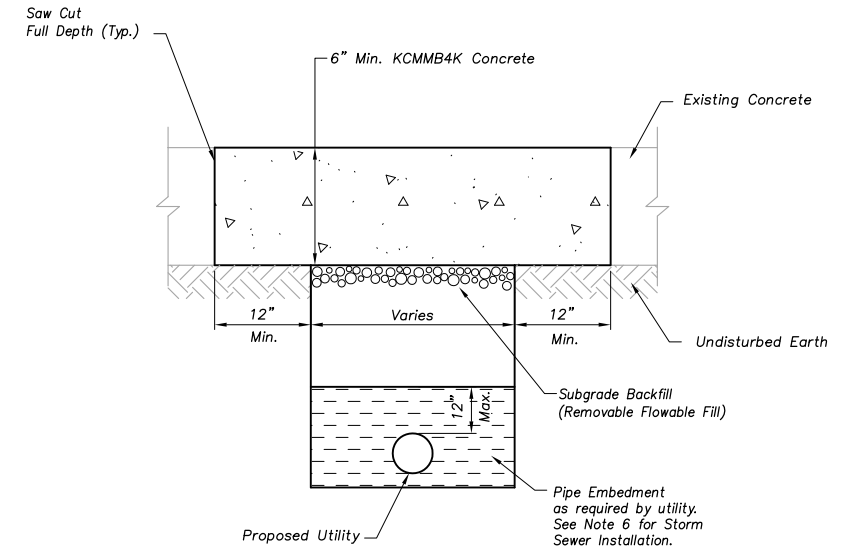

**Portland Cement
Concrete Street Repair ****

** - May be Used Only on Existing Concrete Streets

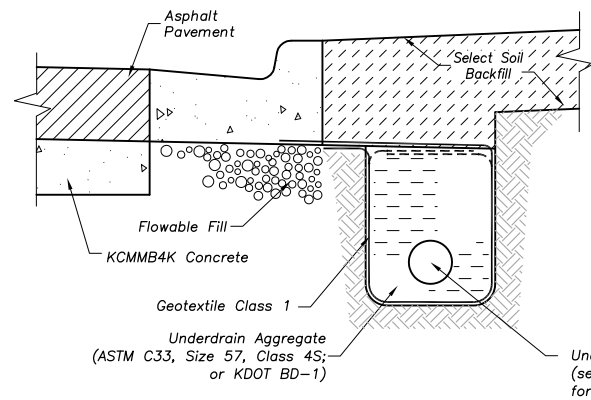

Pipe Underdrain Repair

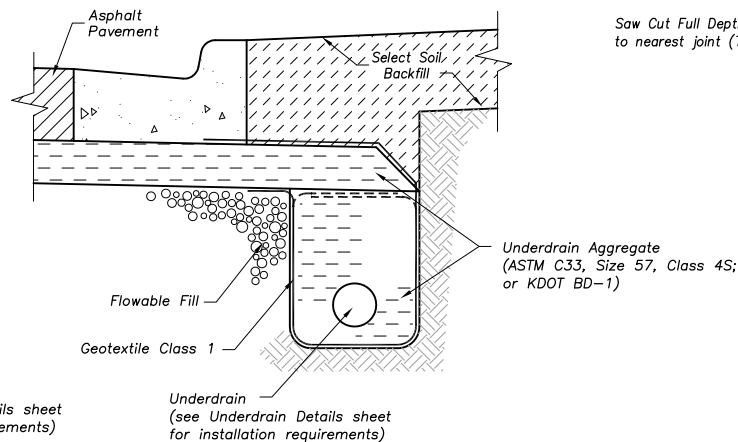

**Pipe Underdrain Repair
with OP Special**

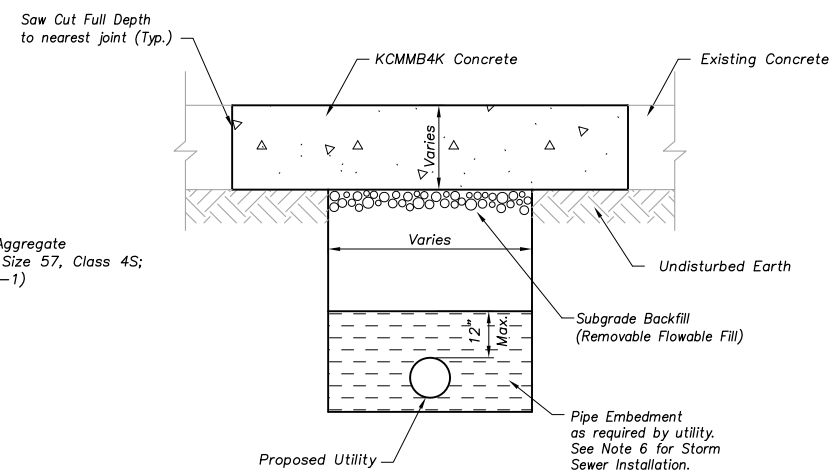

**Repair Under Curb,
Sidewalk or Driveway**

Repair under curb/sidewalk/driveway notes:

1. Curbs, sidewalks and driveways shall be sawed full depth, removed and replaced to nearest contraction or expansion joint.
2. If adjacent section of curb, sidewalk or driveway is cracked, chipped or otherwise damaged, it shall also be removed and replaced to nearest joint.
3. All concrete used in this work shall be KCMMB4K.

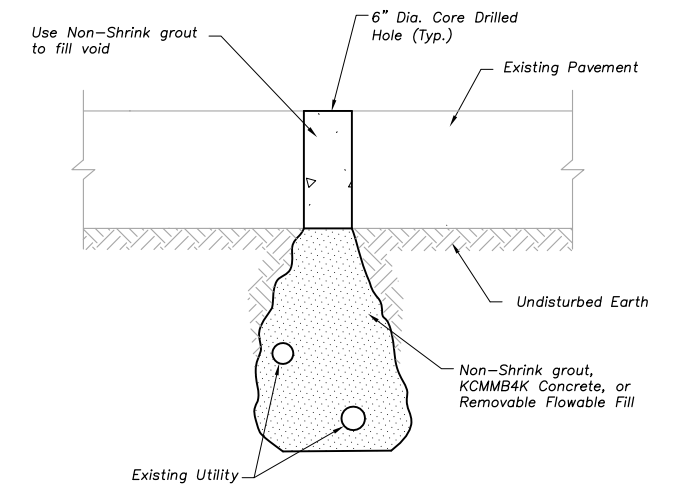

**Utility Investigation
Excavation Repair *****

*** - for repair areas under 1 s.f.

Utility Investigation Excavation Repair Notes:

1. For repair areas greater than 1 s.f. or non-core drilled pavement cut see Street Repair Detail.
2. Non-shrink grout, having a minimum compressive strength of 3000 psi in 24 hours shall conform to ASTM C1107.
3. Contact the City Representative regarding approved bonding agent.

Street Repair Notes:

1. Overland Park Municipal Code (OPMC) and Overland Park Design and Construction Standards Manual (OPDCSM) are incorporated, except as otherwise noted. In restoring the Right-of-Way, the Permittee guarantees its work and shall maintain it for 24 months following its completion.
2. The Manual on Uniform Traffic Control Devices, the Overland Park Traffic Control Handbook for Street Maintenance and Construction Operations, and the latest edition of the O.P. Manual of Infrastructure Standards are incorporated except as otherwise noted.
3. Any excavation left open overnight in any roadway shall be securely plated. Plates shall be properly anchored and all edges of the plate shall be ramped with asphalt surface mix to prevent rattling.
4. All KCMMB4K Concrete, removable flowable fill and asphaltic concrete shall conform to OPMC Title 13.

5. When trenching through OP Special Aggregate Base, flowable fill shall be used to backfill the trench to the elevation of the bottom of the OP Special Aggregate Base, then backfilled and compacted to the bottom of pavement with ASTM C33, Size 57, Class 4S aggregate.
6. For Storm Sewer Installation pipe embedment shall be filled no higher than the pipe springline elevation.
7. Permanent pavement markings shall be replaced with like materials within fourteen days after the pavement surface has been replaced, unless otherwise authorized by the City Engineer.

STREET REPAIR

No Scale

REVISIONS:	
02/15/00	Street Repair Types; Notes;
07/01/03	Concrete Mix Designation;
Jan. 2008	Miscellaneous;
Feb. 2008	OPMC Reference;
RELATED ORDINANCES:	
OPMC Title 13	



DEPARTMENT OF PUBLIC WORKS
STANDARD DETAILS

STREET REPAIR DETAILS

Year 2016 Edition

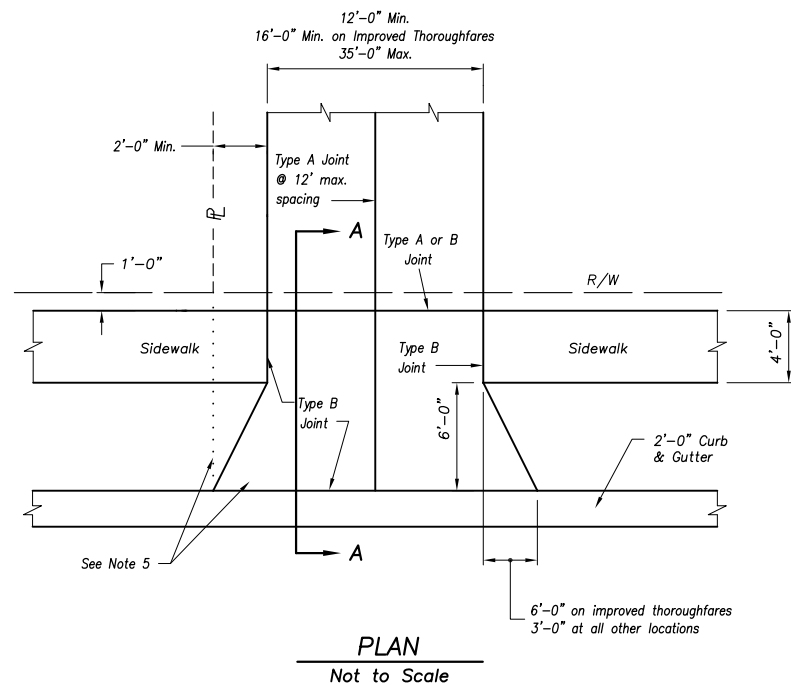

PLAN
Not to Scale

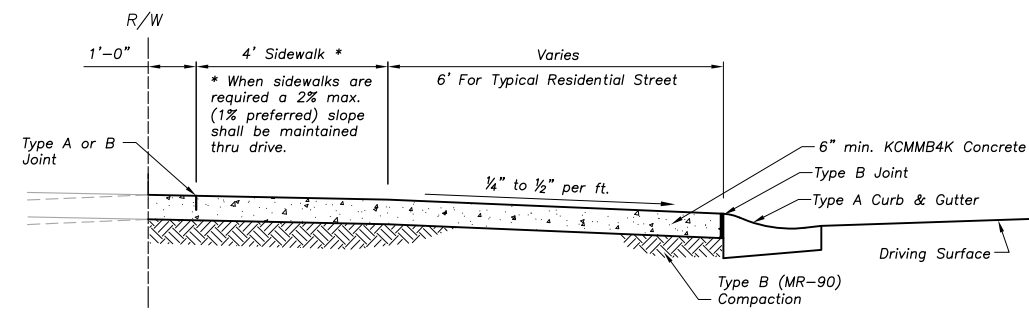

SECTION A-A
Not to Scale

Residential Driveway Notes:

- Overland Park Municipal Code (OPMC) and Overland Park Design and Construction Standards Manual (OPDCSM) are incorporated, except as otherwise noted.
- KCMB4K Concrete shall be used throughout.
- Sidewalk is located one foot from the right-of-way line, therefore position of sidewalk in relation to the 3'-0" x 6'-0" transition may vary.
- Grading within the right-of-way to be as per the Typical Section and Plans.
- Driveway wing shall not extend past side property line extension. Driveway wing dimensions may require modification to ensure encroachment on adjacent property does not occur.
- Concrete pavement shall be jointed with Type A joints. No jointed slab shall exceed 12' x 12'.
- Sidewalk, abutting driveway entrance, must be replaced if the elevation of new driveway entrance does not match that of existing sidewalk.

RESIDENTIAL DRIVEWAY

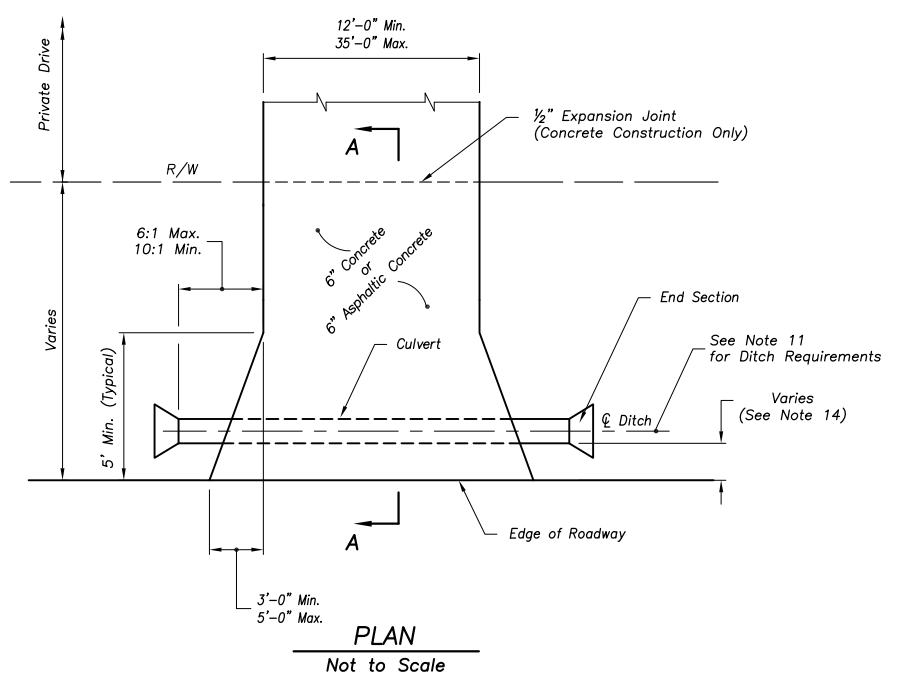

PLAN
Not to Scale

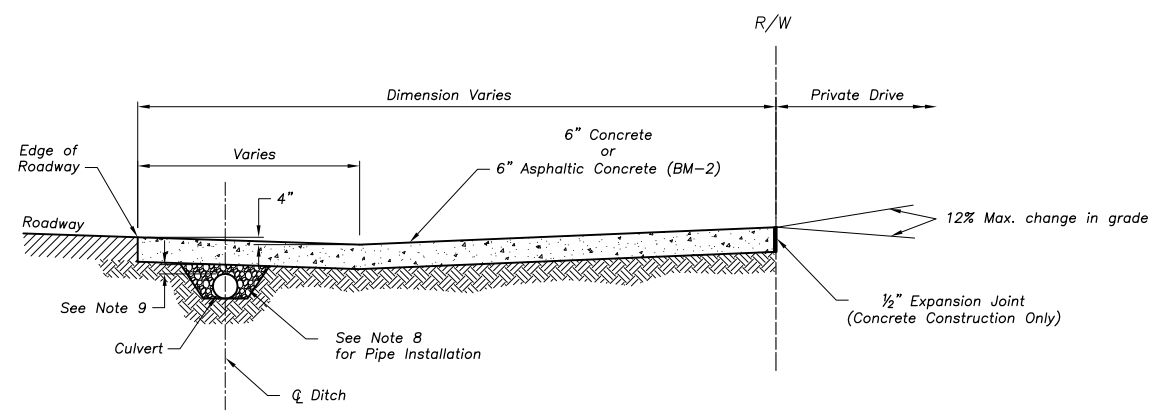

SECTION A-A
Not to Scale

Driveway Entrance on Non-Curbed Streets Notes:

- Overland Park Municipal Code (OPMC) and Overland Park Design and Construction Standards Manual (OPDCSM) are incorporated, except as otherwise noted.
- KCMB4K concrete shall be used throughout.
- Culvert diameter to be approved by the City Engineer. The size of the drive culvert shall be a minimum of 12" diameter and designed for at least a 10-year storm event. The slope of the pipe shall be a minimum of 0.5%.
- Minimum culvert length is 24 feet, or driveway width plus 10 feet.
- Culvert shall be RCP or HDPE, meeting the City's specifications for storm pipe. CMP pipe is not allowed.
- Bell-and-Spigot gasketed joints or manufactured coupling bands are required with HDPE.
- Inspection of driveway forms is required prior to pouring of concrete.
- Compacted granular backfill is required with HDPE. The backfill material shall be ASTM Class 1 Material, KDOT PB-3, or as approved by the City Engineer. There shall be a minimum of 12" cover for HDPE pipe.
- Refer to the City of Overland Park RCP Installation Standard Detail for guidance. There shall be a minimum of 6" cover for RCP pipe.
- Top of concrete to be level with road surface.
- Ditch needs to be cleaned both upstream and downstream. Obtain 2.5% minimum slope in the ditch. Refer to the City of Overland Park R.E. District Ditch Street Typical Section Standard Detail for additional requirements.
- Slopes transverse to the public street (e.g., driveway side slopes) should be as flat as practical. Where practical a slope of 1 vertical to 6 horizontal (1V:6H) or flatter shall be constructed with a minimum slope of 2.5% being allowed. In no instance shall the slope exceed 1V:4H without specific City approval.
- Driveway culverts:
 - Shall be placed as far away from the public roadway as practical.
 - Shall be cut to match the driveway slope.
 - Depending on location may require bar grates or other end treatment when larger than 24" in diameter.
 - Shall have delineators placed at each end for hazard identification.
- Refer to the current addition of the AASHTO Roadside Design Guide for additional information on the construction of the driveway and the placement of the driveway culvert to allow sufficient clear zone and flare rates.

DRIVEWAY ENTRANCE ON NON-CURBED STREETS

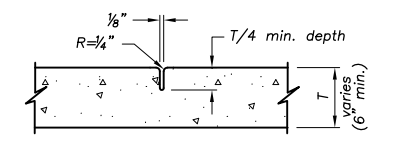

Type A (Contraction)

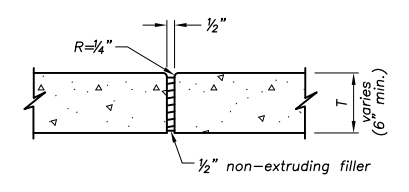

Type B (Isolation)

JOINT DETAILS

Not to Scale

Year 2016 Edition

REVISIONS:	
02/15/00	Compaction Type; Notes;
07/01/03	Concrete Mix Designation;
Jan. 2009	Driveway Entrance on Non-Curbed Streets;
RELATED ORDINANCES:	
OPMC Title 13	

OVERLAND PARK
KANSAS
ABOVE AND BEYOND. BY DESIGN.

DEPARTMENT OF PUBLIC WORKS
STANDARD DETAILS

RESIDENTIAL DRIVE DETAIL

DATE: 09/28/99 SHEET: 18

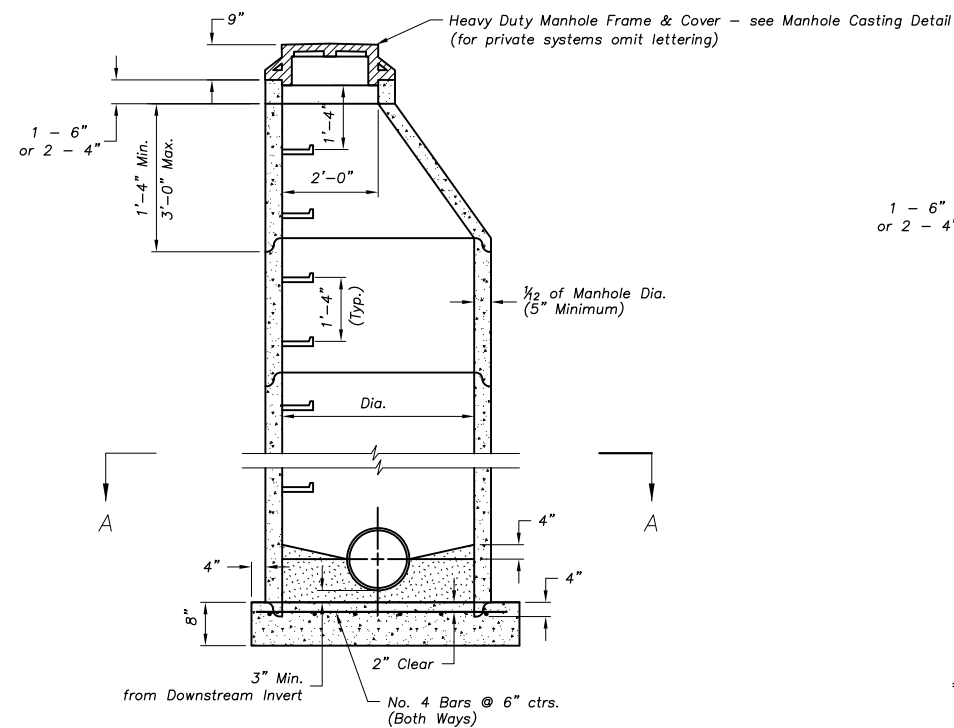

STANDARD PRECAST MANHOLE
(ECCENTRIC CONE)
 Not to Scale

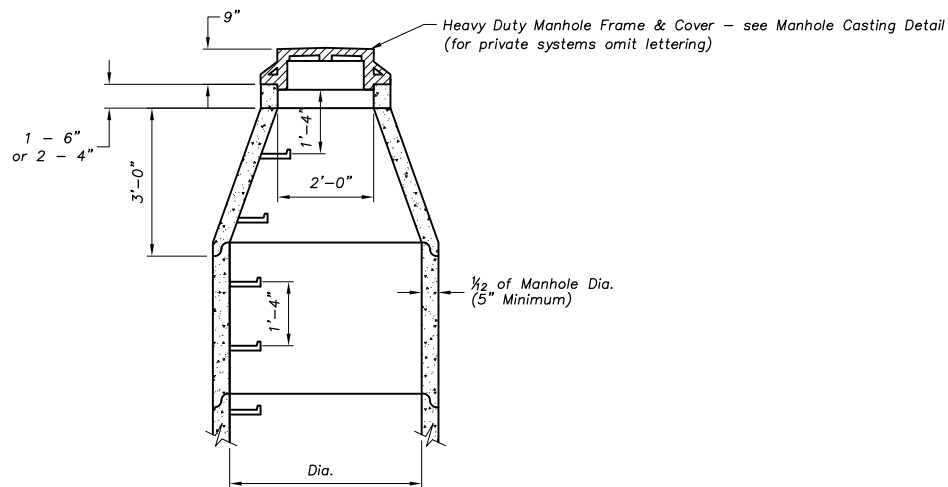

STANDARD PRECAST MANHOLE
(CONCENTRIC CONE)
 (Shallow Manholes only)
 Not to Scale

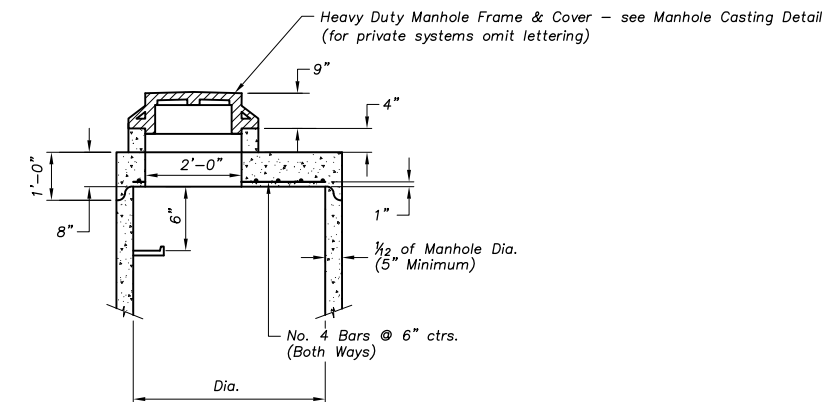

STANDARD PRECAST MANHOLE
(SHALLOW TYPE)
 (To be Used Only When Specified in Plans)
 Not to Scale

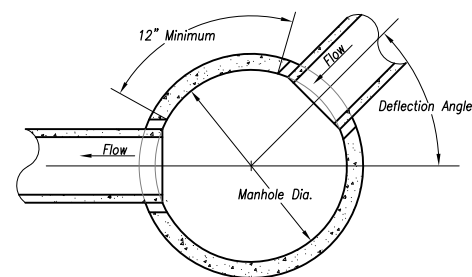

SECTION A-A
 Not to Scale

Precast Manhole Notes

1. Overland Park Municipal Code (OPMC) and Overland Park Design and Construction Standards Manual (OPDCSM) are incorporated, except as otherwise noted.
2. The inside diameter of the manhole shall be 4'-0" for pipe diameters from 12" thru 24". All manhole bases (pre-cast or poured-in-place) shall have No. 4 reinforcing bars placed at 6" centers both ways.
3. All manhole rings and covers shown in plans shall be heavy duty.
4. Standard cast iron manhole steps or steel core, plastic coated steps may be used. See Approved Materials List for pre-approved steps.
5. Reinforcement in all sections shall equal or exceed A.S.T.M. C-478 specifications.
6. Mastic material to be used at all sections joints. O-rings may be used for joints below the cone section, but the cone section itself shall not have O-ring joints.
7. Approved gasket or concrete mortar to be used around pipe in knock-outs.
8. Pipe connections to pre-cast structures shall have a minimum of 6" of concrete around the entire pipe within 2' of the structure.

Year 2016 Edition

REVISIONS:	
05/10/01	Notes;
07/01/03	Miscellaneous;
Jan. 2006	Miscellaneous;
RELATED ORDINANCES:	
OPMC Title 15	

OVERLAND PARK
 KANSAS
 ABOVE AND BEYOND. BY DESIGN.

DEPARTMENT OF PUBLIC WORKS
 STANDARD DETAILS

PRECAST MANHOLE DETAIL

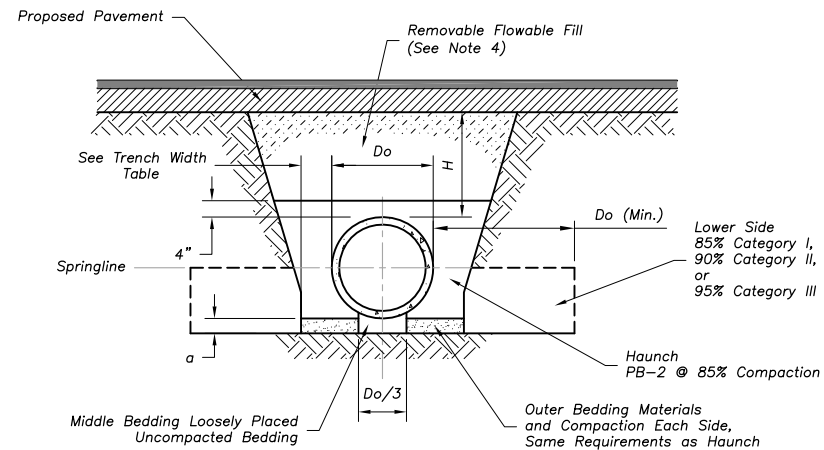

Trench Installation under Paved Surface

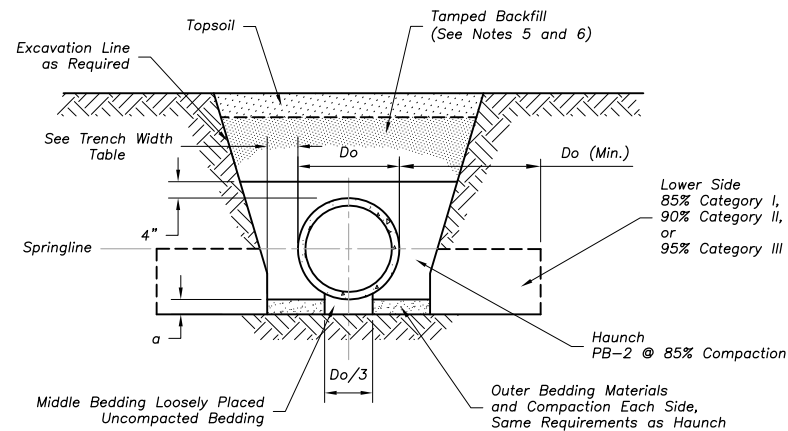

Trench Installation outside Paved Surface

RCP installation notes:

1. Overland Park Municipal Code (OPMC) and Overland Park Design and Construction Standards Manual (OPDCSM) are incorporated, except as otherwise noted.
2. Category I material shall be crushed stone or siliceous gravel meeting the requirements of Section 1107 of the Standard Specifications, Aggregate Designation PB-2.
3. Compaction and soil symbols – i.e. "95% Category I" – refers to Category I soil material with minimum standard Proctor compaction of 95%.
4. Removable Flowable Fill is required for the full depth of the trench as shown on the Trench Installation detail in any paved portion of the right of way, including the area within existing or future public street pavement, under existing or future curb and gutter, median, asphalt path, parking lots, concrete sidewalk. Also under existing concrete, asphalt, or gravel driveway approach and under any future driveway approach, when the location is known. Flowable Fill shall be considered subsidiary to the pipe installation.
5. Tamped backfill shall be used at all other locations unless otherwise noted. Tamped backfill shall be finely divided job excavated material free from debris, organic material and stones, compacted to 95% maximum density as determined by AASHTO STANDARD, Method T-99.
6. Granular fill may be substituted for all or part of tamped backfill. Granular fill shall be AB-3 OP Modified, as specified in the Standard Specifications, compacted to a minimum of 95% of optimum density, within 0 to minus 2 percent of optimum moisture placed up to an elevation 6" below surface. Topsoil shall be used in the top 6".
7. When the existing grade is not at least 18" above the proposed top of pipe profile, install compacted fill (95% Std. Proctor) to 18" above top of pipe prior to excavation for storm sewer installation, or as approved by the City Engineer.
8. Soil in outer bedding and haunch zones shall be compacted to at least the same compaction as specified for the majority of soil in the backfill zone.
9. The trench width shall be wider than shown if required for adequate space to attain the specified compaction in the haunch and bedding zones.
10. For trench walls that are within 10 degrees of vertical, the compaction or firmness of the soil in the trench walls and lower side zone need not be considered.
11. For trench walls with greater than 10 degree slopes that consist of embankment, the lower side shall be compacted to at least the same compaction as specified for the soil in the overfill zone.
12. See street repair details for additional backfill requirements under streets roadways, curbs, sidewalks and other structures in Right-of-Way.

TRENCH WIDTH TABLE

Pipe Size (inches)	Minimum Side Wall Clearance (inches)
12 - 18	6
21	6.5
24	7
27	8
30	8.5
33	9
36	10
42	11
48	12.5
54	13.5
60	15
66	15
72	15.5
78	15.5
84	16
90	16.5
96	17
102	17.5
108	18

TABLE OF FILL DEPTHS BELOW PIPE

D	"a" min. in Soil	"a" min. in Rock
60" & smaller	3"	6"
66" & larger	6"	12"

RCP INSTALLATION

No Scale

Year 2016 Edition

REVISIONS:	
02/15/00	RCP Installation Types I, II, III;
05/20/03	RCP Installation Notes;
Feb. 2008	Aggregate Designation
RELATED ORDINANCES:	
OPMC Title 15	

OVERLAND PARK
KANSAS
ABOVE AND BEYOND. BY DESIGN.

DEPARTMENT OF PUBLIC WORKS
STANDARD DETAILS

RCP INSTALLATION DETAIL

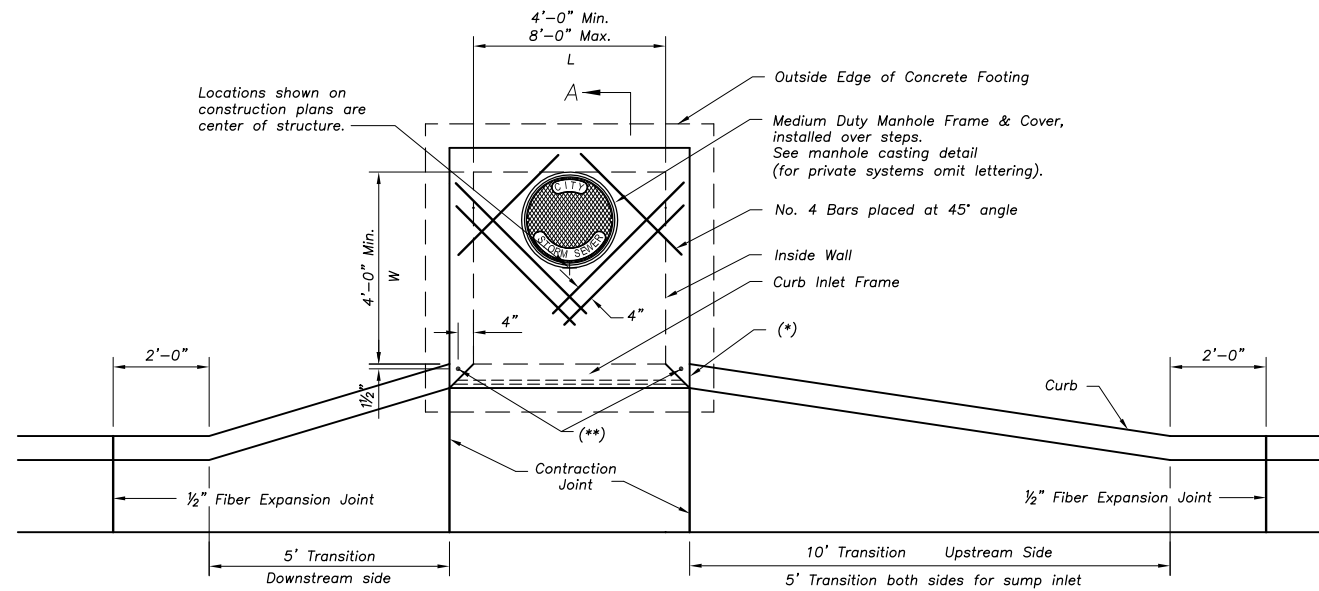

Plan
Not to Scale

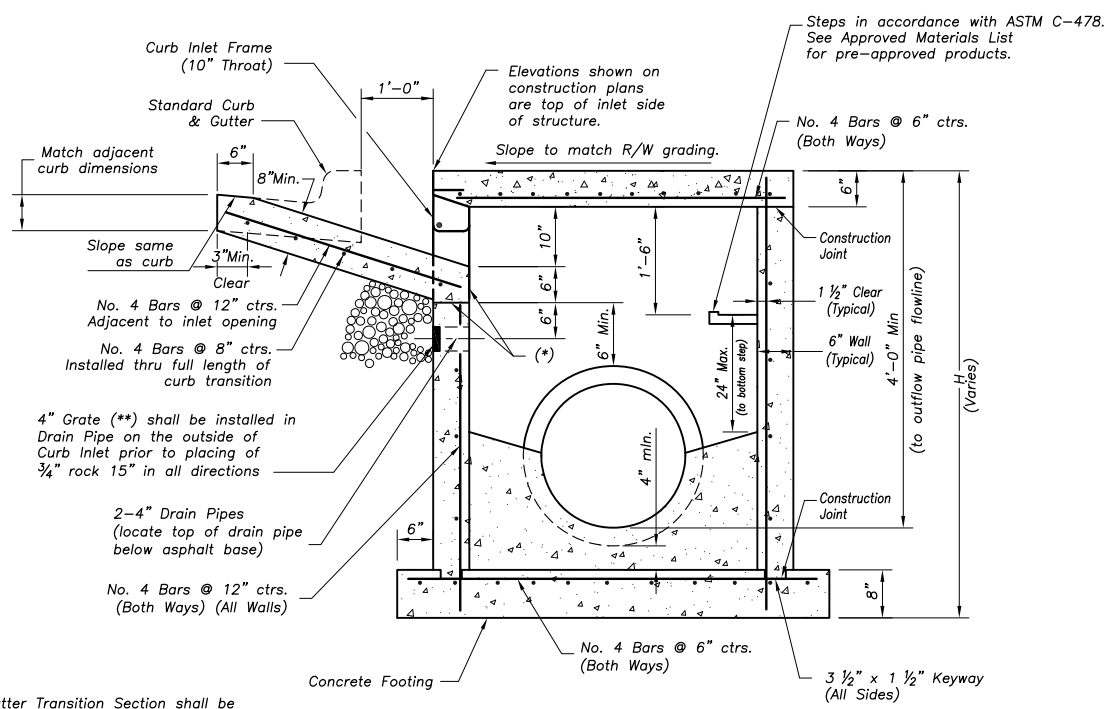

Section A-A
Not to Scale

CURB INLET (10" THROAT)

- (*) - Curb & Gutter Transition Section shall be isolated from Curb Inlet at all points of contact. Isolation material shall be 30 lb. Roofing Felt or approved equal.
- (**) - the material of the grate shall match the material of the pipe and shall be as follows:
 - a) PVC: Pipe - 4" Schedule 40 PVC meeting ASTM D-1785'; Grate - 4" PVC Snap-in Drain - meets ASTM D-2665, with Stainless Steel (Type 304) Cover, mounted with two 18-8 Stainless Steel Screws; Maximum opening size 1/4".
 - b) HDPE: Pipe - 4" HDPE meeting AASHTO M252, Type S; Grate - 4" HDPE - meets ASTM D-3350; Maximum opening size 1/4".

Curb Inlet Notes

General

1. Overland Park Municipal Code (OPMC) and Overland Park Design and Construction Standards Manual (OPDCSM) are incorporated, except as otherwise noted.
2. All storm sewer structures shall be pre-cast or poured in place. If pre-cast structures are used, the tops shall be poured in place and the wall steel shall be left exposed to a height 2" below the finish top elevation, or as directed by the City Engineer.
3. Pre-cast shop drawings are to be approved by the City Engineer for publicly financed or administered projects. Pre-cast shop drawings for privately financed projects are to be submitted to the Engineering Services Division of the Planning and Development Services Department.
4. Do not scale these drawings for dimensions or clearances. Any questions regarding dimensions shall be brought to the attention of the City Engineer prior to construction.
5. On-grade inlets shall conform to the street grade and sump inlets shall be level.
6. The first dimension listed in the construction notes is the "L" dimension. The second dimension is the "W" dimension. The concrete thickness and reinforcement shown is for boxes with ("L"+"H") and ("W"+"H") less than or equal to 20. For boxes with either of these calculations greater than 20, a special design is required.

Concrete

7. Concrete used in this work shall be KCMMB4K, as approved by the Kansas City Metropolitan Materials Board, and shall meet the requirements of the OPMC.
8. Inlet floors shall be shaped with non-reinforced concrete inverts to provide smooth flow.
9. Bevel all exposed edges with 3/4" triangular molding.

Reinforcing Steel

10. Reinforcing steel shall be new billet, minimum Grade 40 as per ASTM A615M, and shall be bent cold.
11. All dimensions relative to reinforcing steel are to centerline of bars. 2" clearance shall be provided throughout unless noted otherwise. Tolerance of +/- 1/8" shall be permitted.
12. All lap splices not shown shall be a minimum of 40 bar diameters in length.
13. All reinforcing steel shall be supported on fabricated steel bar supports @ 3'-0" maximum spacing.
14. All dowels shall be accurately placed and securely tied in place prior to placement of bottom slab concrete. Sticking of dowels into fresh or partially hardened concrete will not be acceptable.

Construction

15. The bottom slab shall be at least 24 hours old before placing sidewall concrete. All sidewall forms shall remain in place a minimum of 24 hours after sidewalls are poured before removal, and after removal shall be immediately treated with membrane curing compound.
16. All curb inlet tops are to be constructed after final curb string line has been approved by the Engineer and prior to curb construction, or as directed by the City Engineer.
17. Pipe connections to pre-cast structures shall have a minimum of 6" of concrete around the entire pipe within 2' of the outside wall of structure. A minimum of 2" - maximum of 6" clearance is required between the outside pipe wall and the edge of blackout.
18. Tamped backfill shall be used around structures, except under paved areas. Tamped backfill shall be finely divided job excavated material free from debris, organic material and stones, compacted to 95% maximum density as determined by AASHTO STANDARD, Method T-99. Removable Flowable Fill is required under any portion of paved right of way, including the area within existing or future public street pavement and under existing or future curb and gutter, median, asphalt path, concrete sidewalk.

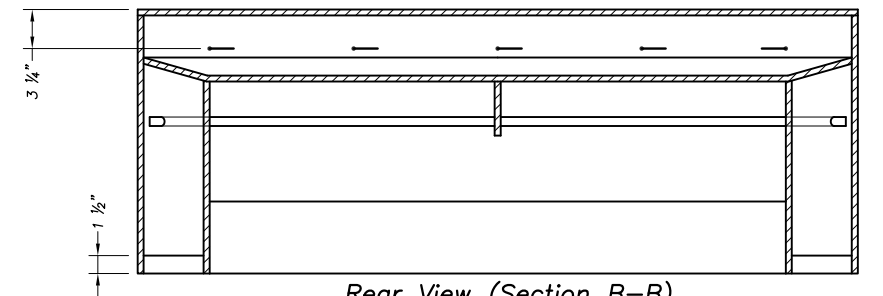

Rear View (Section B-B)
Not to Scale

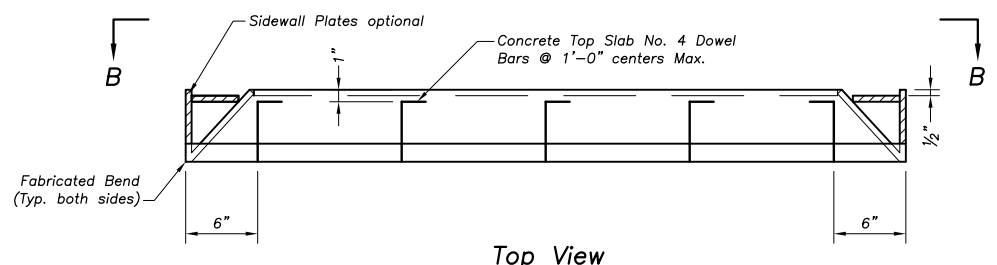

Top View
Not to Scale

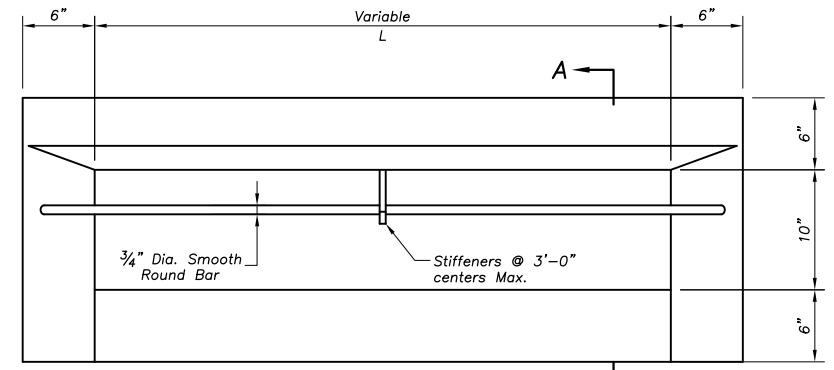

Front View
Not to Scale

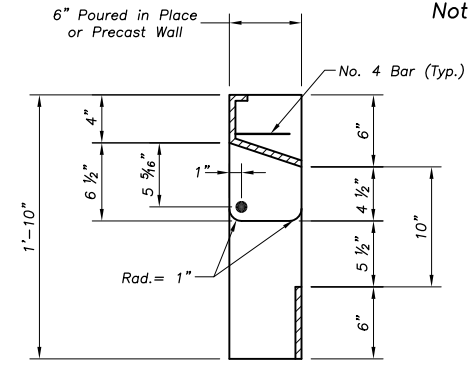

Side View (Section A-A)
Not to Scale

Curb Inlet Frame Notes

1. All welds shall be performed in accordance with appropriate AWS Specifications and Procedures.
2. All welds on exposed surfaces shall be dressed so as to provide a pleasing finished appearance.
3. All flat steel shall be 7 Gage or 3/16" thick.
4. The entire frame shall be hot dip zinc coated in accordance with ASTM A-123.

CURB INLET FRAME (10" THROAT)

REVISIONS:	
07/01/03	Concrete Mix Designation;
March '05	Inlet Frame Details;
Jan. 2006	Miscellaneous;
Jan. 2013	Inlet Frame Details;
RELATED ORDINANCES:	
OPMC Title 15	

Year 2016 Edition

OVERLAND PARK
KANSAS
ABOVE AND BEYOND. BY DESIGN.

DEPARTMENT OF PUBLIC WORKS
STANDARD DETAILS

CURB INLET DETAILS

DATE: 09/28/99 SHEET: 22

2017 STORM SEWER POINT REPAIRS, CONTRACT 1

MISSION, JOHNSON COUNTY, KANSAS

SECTIONS 5 & 8, TOWNSHIP 12S, RANGE 25E

UTILITY COMPANIES

Fiber	American Fiber Systems (801) 364-1063
Fiber	Consolidated Communications 14859 West 95th St. Shawnee Mission, KS 66215 (800) 778-9140
Fiber	Google Fiber (913) 486-5018
Gas	Kansas Gas Service (800) 778-9140
Telephone	Centurylink (800) 850-9048; (800) 283-4237
Telephone	US Sprint 6391 Sprint Pkwy Overland Park, KS 66251-4300 (913) 534-7100
Public Works	City of Mission 4775 Lamar Ave Mission, KS 66202 (913) 676-8375
Sanitary Sewer	Johnson County Wastewater 4800 Nall Ave Mission, KS 66202 (800) 778-9140
Water	WaterOne 10747 Renner Boulevard Lenexa, KS 66219 (913) 895-1800
Locates	Kansas One Call System, Inc.

PERMITS

The Contractor shall be responsible for obtaining all required construction permits, paying all fees, and otherwise complying with all applicable regulations governing the work and the cost shall be subsidiary to other bid items.

Contractor shall utilize Best Management Practices to control erosion and sediment migration into storm drainage structures or channels. Contractor shall evaluate drainage patterns and provide erosion control devices necessary. Contractor shall keep 150 LF of 9" wattle on site for temporary slope protection during construction. The wattle may be moved at the direction of the Owner or Engineer for temporary erosion control during construction. The wattle may be removed or left in place at the direction of the Owner or Engineer when the site is 70% revegetated.

The Contractor shall halt construction immediately and contact the Kansas State Historical Society should artifacts of questionable historical relevance be discovered during excavation.

UTILITY NOTES

The information concerning the location of underground utilities shown hereon, which are not visible from the surface, has not been verified in the field. These locations are not to be construed as accurate or exact. Before beginning any construction or excavation, please call Kansas One-Call System, Inc. at 1-800-344-7233.

CONSTRUCTION NOTES

- Notify property owners prior to beginning work and disrupting driveway access.
- Before starting excavation activities, the Contractor shall notify all utilities involved, and shall request them for cooperation effort to avoid breaking utility lines. The utility shall be notified immediately should a break occur in a line during construction under this contract. Any lines so broken by the Contractor shall be repaired according to the utility company's standards at the expense of the Contractor. The Contractor shall be held responsible for contacting all utility companies for field location of all underground utility lines, whether shown on these plans or not, prior to any excavation.
- The Contractor shall provide protection to prevent undermining or damage to the structural integrity of all utility poles, fences, road signs, or other items that parallel or cross the site and make arrangements with owning entity to provide temporary support or protection during construction.
- Existing private sanitary sewer facilities serving buildings may not be shown. The Contractor shall be held responsible for any damages done to these facilities during construction, and shall maintain continuous service to all buildings.
- Construction activity (including demolition, clearing, storage of equipment and materials, installation of materials and equipment, and employee parking) shall be restricted to street right-of-way and City of Mission-owned property, permanent and temporary easements, and along with other areas secured by Contractor by private agreement. Engineer shall be informed of Contractor's private arrangements for construction easements and shall be supplied a copy of the written agreement.
- Use of the Site: Limit use of the premises to work in areas indicated. Do not disturb portions of the site beyond the areas in which the work is indicated.
- Traffic control shall conform to the requirements of the City of Mission. All proposed road closures will require traffic control plans with proposed detour route, permit, and permission of the Owner in advance of the proposed work. Parking may be prohibited during construction. Through traffic will be maintained at all times on all streets being where work is occurring, unless otherwise agreed to by the City of Mission.
- Roads and Driveways: Keep roads and driveways clear and available to the residents and emergency vehicles at all times. Do not use these areas for parking or storage of materials. Provide temporary surfacing as necessary to maintain access. Schedule deliveries to minimize space and time requirements for storage of materials and equipment on-site.
- Contractor shall identify where on-street parking must be temporarily prohibited. Contractor shall provide temporary signs and direct the installation. Contractor shall provide labor and equipment for installation and subsequent removal of temporary signs. Temporary parking prohibitions shall be posted at least 48 hours in advance of the effective date of parking prohibition.
- All excavation shall be Unclassified Excavation.
- Contractor shall restore the project sites to conditions equal to or better than those existing prior to entry. All existing items and construction removed or damaged during the performance of the Work, regardless of location and whether or not indicated on these Contract Drawings, shall be repaired or replaced as detailed in the Contract Specifications unless otherwise indicated on these Contract Drawings.
- Pavement restoration shall involve restoration of paved surfaces with similar materials in accordance with the City of Mission Standards as currently adapted.
- In residential or commercial areas, turf restoration shall be sod. Turf restoration of vacant lots and in agricultural, industrial, or unmaintained areas, turf restoration may be seed and mulch, abandoned houses may be either seed or sod.
- Backfill in street or alley right-of-way and under pavement or within 4 feet horizontal of pavement shall be flowable fill (60 to 90 psi).
- Backfill in areas other than street or alley right-of-way shall be acceptable excavated material.

GENERAL NOTES

This project shall be constructed in accordance with the Specifications and Contract Documents. All work in public easements and Right-of-Way and all erosion control work must comply with the latest edition of the Overland Park Construction Details.

The Contractor shall have one (1) signed copy of the plans and one (1) copy of the appropriate construction specifications at the job site at all times.

The Contractor shall carefully preserve all monuments, reference points, stakes, and bench marks set for project control, and in case of destruction of same through carelessness or negligence on the part of the Contractor, he will be charged with the resulting expense of replacement and responsibility for any mistakes or loss of time caused thereby.

The Contractor is responsible for the protection of all property corners and section corners. Any property corners or section corners disturbed or damaged by construction activities shall be reset by a registered land surveyor licensed in the State of Kansas, at the Contractor's expense.

Table of Quantities shown on these plans are for reference for the Base Bid item. The Base Bid bid item may require more items to fully restore the project areas. Items necessary for full restoration of the project area shall be subsidiary to the Base Bid item.

Driveways, sidewalk, pavement and other areas inside and outside the construction limits damaged by the contractor shall be restored to a condition equal to or better than that existed before damage occurred at the Contractor's expense.

Structure placement coordinates shown on plans are for center of structure.

Pipe lengths shown on plan are horizontal distance from center of structure to center of structure.

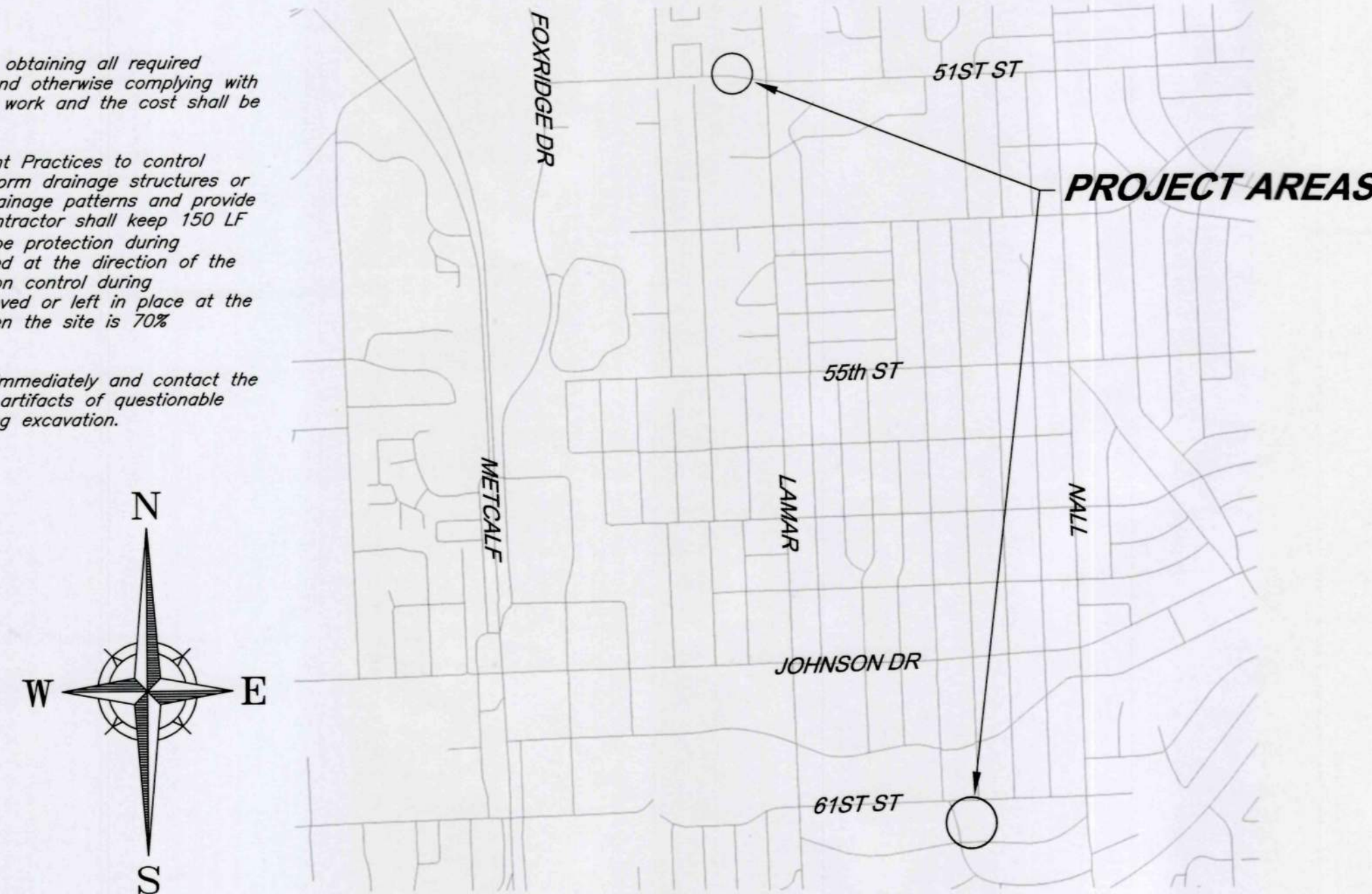

VICINITY MAP

PROJECT BENCHMARKS

6500 W. 51st Street
BM #2983 - Set RR spike in NE face of power pole on South side of 51st Street, 1st pole East of drive to house #6315
Coordinates:
N: 273770.28
E: 2260996.37
EL: 988.33'

5820 W. 61 Terrace
BM #2983 - Chiseled "square" cut on centerline front face of curb inlet at SE corner of 61st St & Woodson Rd.
Coordinates:
N: 267120.08
E: 2283142.34
EL: 969.71'

DEVELOPED AND OWNED BY:
CITY OF MISSION
4775 LAMAR AVENUE
MISSION, KS 66202
913-676-8381
John Belger

PREPARED & SUBMITTED BY:
GEORGE BUTLER ASSOCIATES, INC.
9801 RENNER BOULEVARD
LENEXA, KANSAS 66219-9745

Leslie G. Barnt
PROJECT ENGINEER: Leslie G. Barnt, P.E., CFM



DATE: 3/10/17

INDEX OF SHEETS

Sht. No.	Description
1	Cover Sheet
2-3	Storm Repair Sites

GBA
architects
engineers

9801 Renner Boulevard
Lenexa, Kansas 66219
913.492.0400
www.gbateam.com

C:\13186.11\2017\Production Drawings\Street & Storm Plans\13186_1101502.dwg Layout: Line B -- Wednesday March 08, 2017, 10:01am -- Copyright 2017, George Butler Associates, Inc. Architect 00212, Professional Engineer 000133, Landscape Architect 000025, Professional Land Surveyor 000059

	GBA architects engineers		DATE: 3/8/17
			DESIGN BY: DWC
			DRAWN BY: JVC
		PROJECT NO.: 13186.11	TOTAL SHEETS: 3
		2	3
Leslie G Barnt Professional Engineer License No. 14358		Storm Sewer Improvements 2017 Storm Sewer Point Repairs, Contract 1 City of Mission, Kansas	
NO.	DATE	REVISIONS	BY APPROVED

Notes:
 1. Pipe classification shall be as recommended by pipe manufacturer for the project parameters.
 2. Contractor to verify pipe size to ensure proper fit of pipe plugs at abandonment.

Table of Quantities
 Asphalt Street Repairs - 35 S.Y.
 Concrete Driveway - 20 S.Y.
 Curb and Gutter - 225 L.F.
 4'x3' Precast Concrete Curb Inlet - 3 EA.
 18" Reinforced Concrete Pipe - 248 L.F.
 15" Reinforced Concrete Pipe - 33 L.F.
 Pipe Plugs - 2 EA.
 Flowable Fill - 11 C.Y.

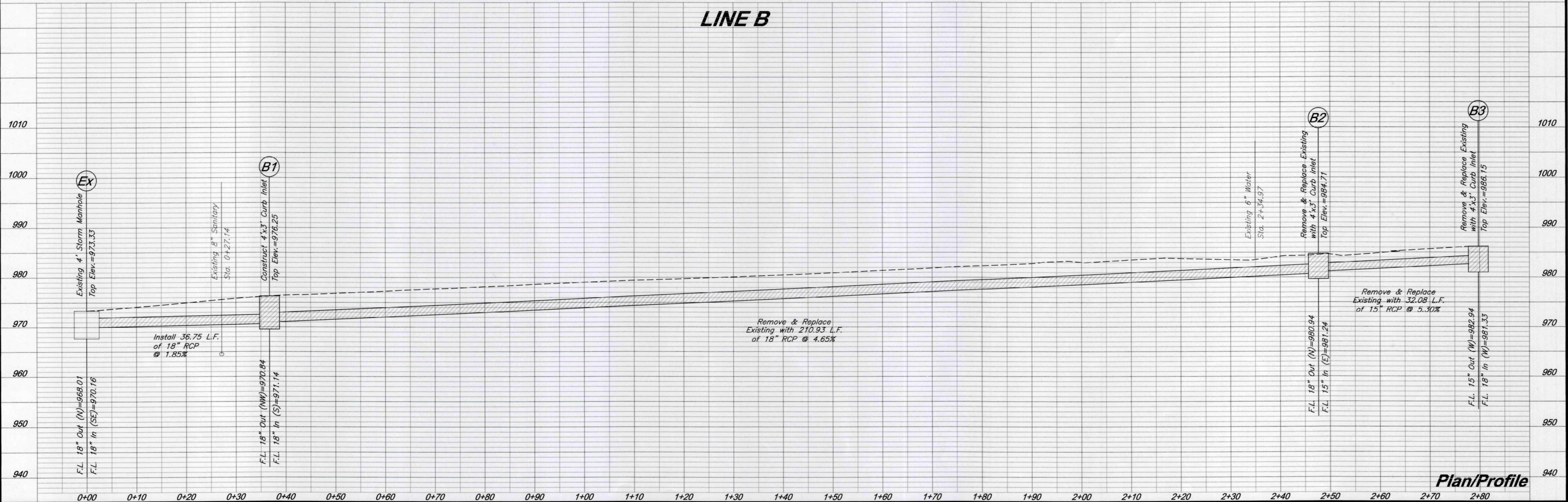
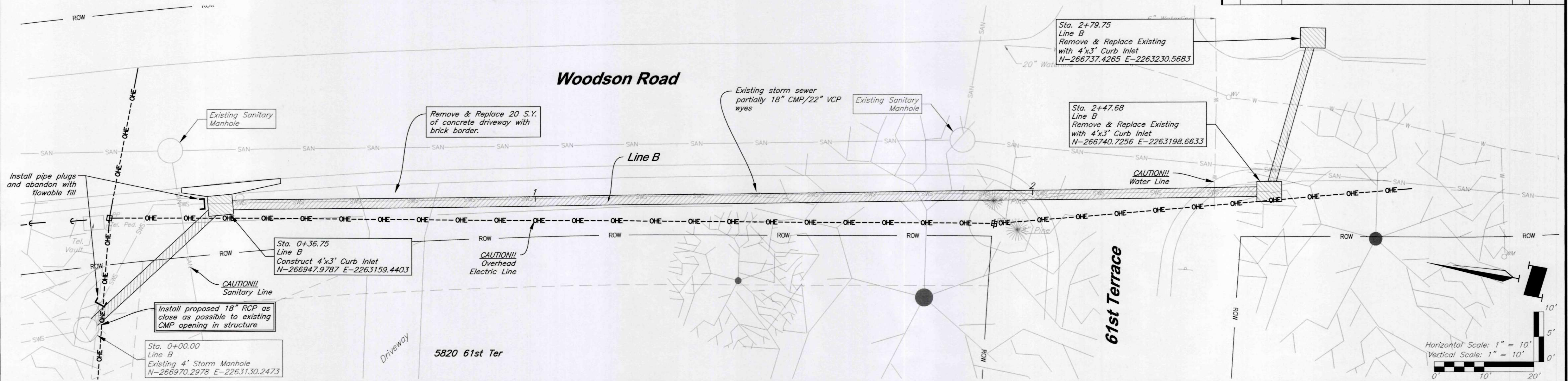

Plan/Profile

G:\13186.11\Drawings\Storm Plans\13186_1101504.dwg Layout: Line D --- Wednesday March 08, 2017, 10:05am --- Copyright 2017, George Butler Associates, Inc. Architect 00212, Professional Engineer 000133, Landscape Architect 000205, Professional Land Surveyor 000099

	GBA architects engineers 9801 Renner Boulevard Lenexa, Kansas 66219 913.492.0400 www.gbateam.com	DATE: 3/8/17 DESIGN BY: DWC DRAWN BY: JVC PROJECT NO.: 13186.11
	Storm Sewer Improvements 2017 Storm Sewer Point Repairs, Contract 1 City of Mission, Kansas	
	SHEET NO. 3	TOTAL SHEETS 3

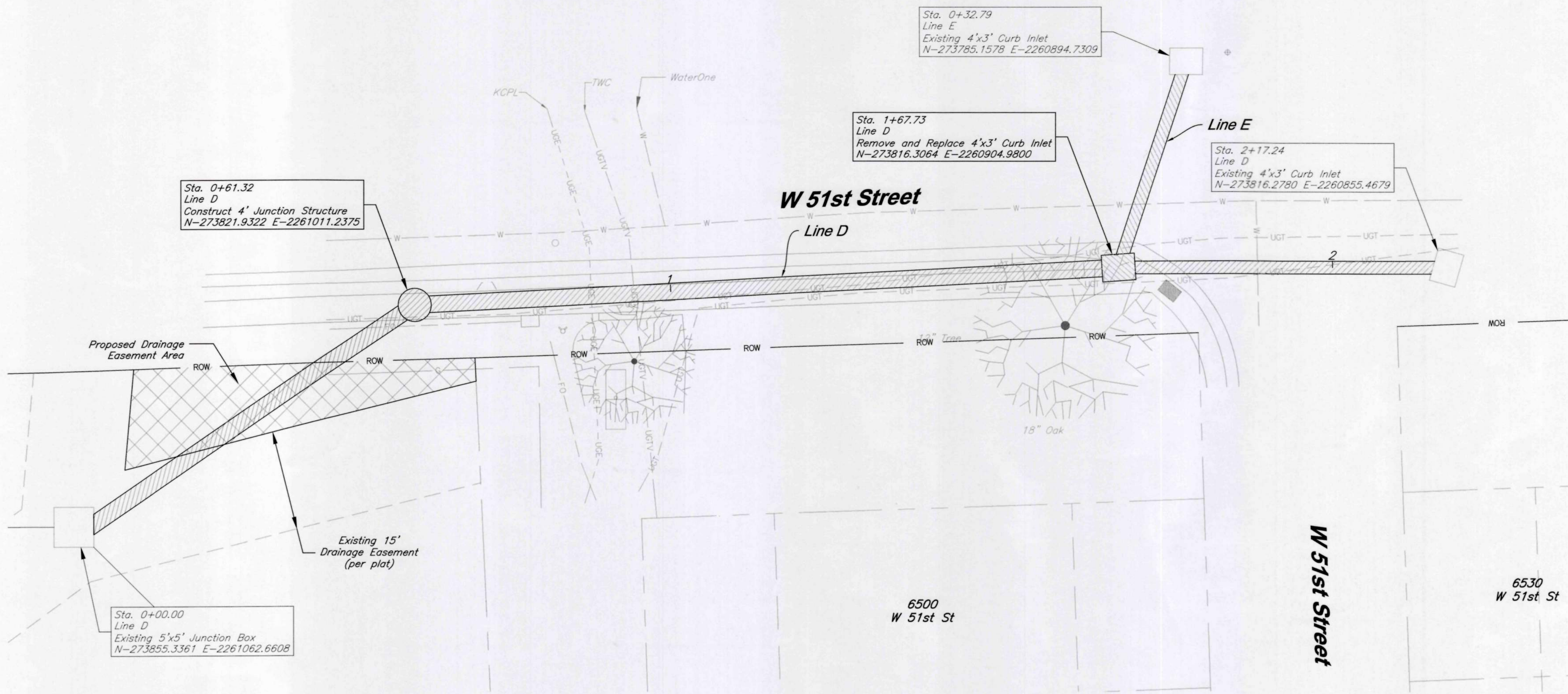
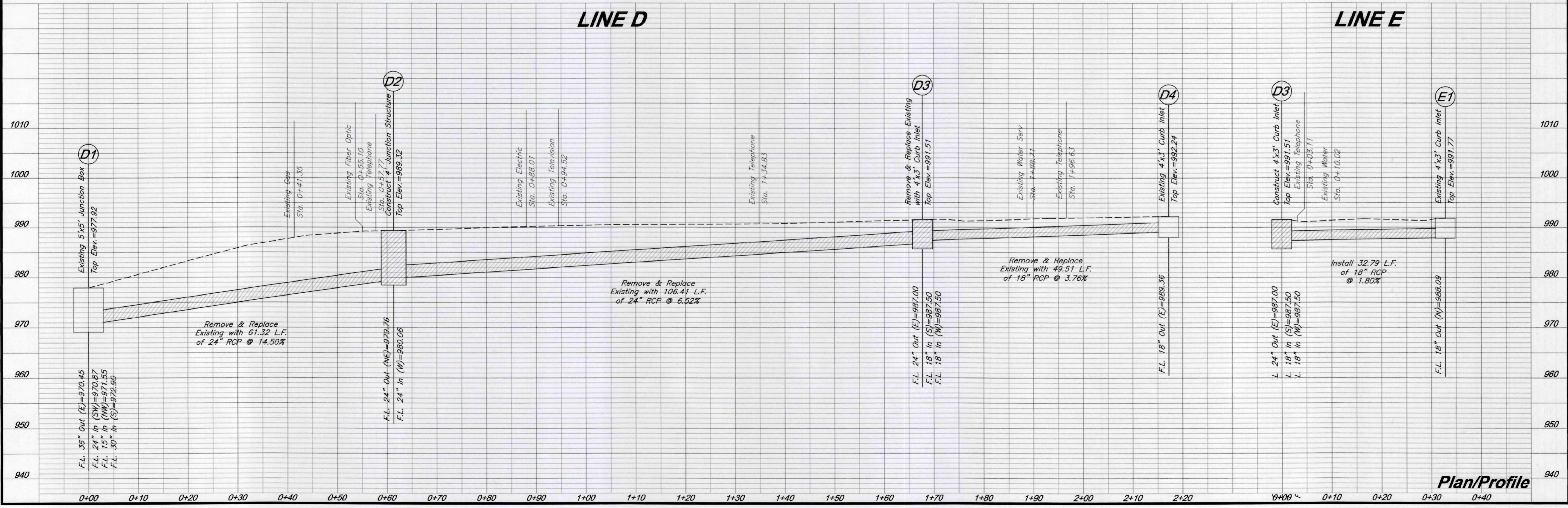
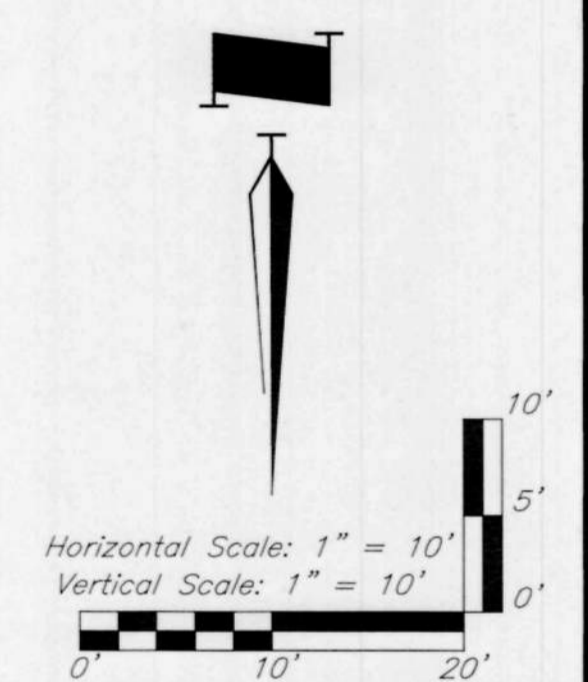

Table of Quantities

- Asphalt Street Repairs - 74 S.Y.
- Curb and Gutter - 131 L.F.
- 4' Concrete Sidewalk - 124 S.F.
- ADA Ramp - 1 EA.
- 4'x3' Precast Concrete Curb Inlet - 1 EA.
- 4' Diameter Precast Storm Manhole - 1 EA.
- 18" Reinforced Concrete Pipe - 83 L.F.
- 24" Reinforced Concrete Pipe - 168 L.F.



City of Mission	Item Number:	6b.
ACTION ITEM SUMMARY	Date:	June 30, 2017
ADMINISTRATION	From:	Laura Smith

Action items require a vote to recommend the item to full City Council for further action.

RE: Street Maintenance Agreement - Kennett Place Subdivision

RECOMMENDATION: Authorize the Mayor to execute an approved “Agreement and Release” document regarding responsibility for street maintenance in the Kennett Place Subdivision.

DETAILS: The City has been in conversation with the Kennett Place Homes Association since 2014 regarding maintenance of the privately owned streets in the subdivision. In 2016, the City Council approved funds to complete a chip seal treatment.

It was later determined that the contractor’s equipment could not pass through Kennett Place’s entrance gates, so staff has been working with the HOA to develop an alternative solution. An agreement and release document is being prepared to not only resolve the 2016 situation, but to provide clear expectations of both parties for the future.

A draft agreement is currently under review by legal counsel for both the City and the Kennett Place HOA.

Update 7/14/2017: Suggested changes to the agreement are still pending from the Kennett Place HOA. If no suggested changes are provided and reviewed prior to the July 19th meeting, the item will be removed from the City Council’s agenda.

CFAA CONSIDERATIONS/IMPACTS: N/A

Related Statute/City Ordinance:	
Line Item Code/Description:	
Available Budget:	\$10,000 (2017)